

# Ukulele UNCAGED

## The **FDCA** System

“**F**lying **D**ogs and **C**ats **A**maze”

For learning the fretboard in depth  
and so to play your music up the neck.

Part two

Finding the notes within the chords

This system for ukulele was adapted from the CAGED system for guitar – the chord names were changed to fit the shapes for uke.

# Ukulele FDCA as a guide to soloing – key of F

## Pentatonic scale and the major chord shapes F, D, C & A

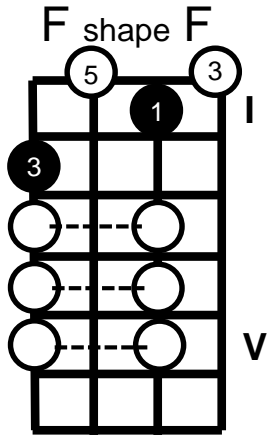

Play the F chord at the neck and familiarize yourself with the note positions – the **F shape has the root on the second string**. So, if you put a bar behind it, knowing the notes on the second string will help you to name the chord. Some landmarks – 3<sup>rd</sup> fret=G, 6<sup>th</sup> fret=Bb, 8<sup>th</sup> fret=C.

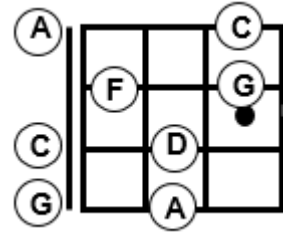

The key of **F** has a major scale associated with it – we'll use a **pentatonic scale** – 5 notes - the 1,2 3 5 and 7 notes of the major scale. See the fretboard map above on the right – the image is the fretboard viewed from the side as if you are looking down on it. Play the first 2 bars of *Swing Low Sweet Chariot* and find the melody on the pentatonic scale. As soon as you recognize that A is the first note, it's easy.

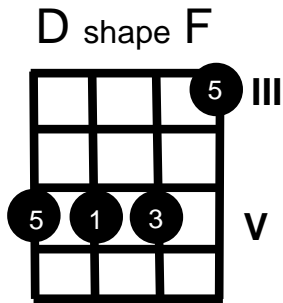

Use the passing chords move up to find the D shape F at frets III and V. Play a **D shape F at frets III and V**. Then keep your ring finger barring the 5<sup>th</sup> fret and play the pentatonic scale at 3<sup>rd</sup> and 5<sup>th</sup>. This scale can be used as a basis to play blues or rock and roll. Find the root on the 3<sup>rd</sup> string and remember CFAD for the notes at the 5<sup>th</sup> fret. Use this F to play the first 2 phrases of the melody for *Tennessee Waltz*.

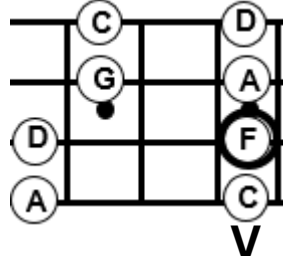

Play the **C shape F at fret V**, and bar the 5<sup>th</sup> fret with your index finger to play the pentatonic scale. You may already be familiar with such a pattern as a "blues box." Play the opening notes of *My Girl*, starting on the root on the third string.

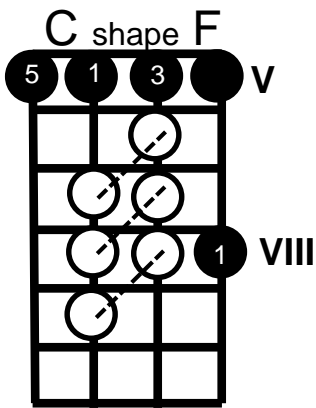
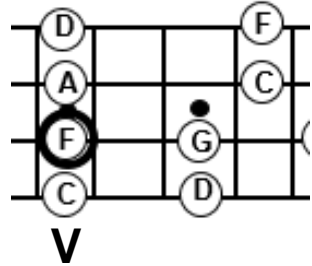

Then, continue to move up the fretboard playing the 1 and 3 notes now found on strings 3 and 2, then the paired notes as passing chords. These can be played in unison or in sequence (arpeggios). Use index and long fingers. Play the **A shape F at fret VIII**. Then start with the 5 (C) at the 8<sup>th</sup> fret 2<sup>nd</sup> string and play the opening for *The Star Spangled Banner*.

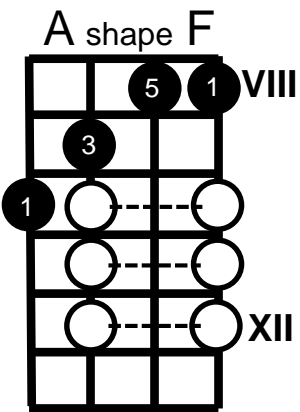
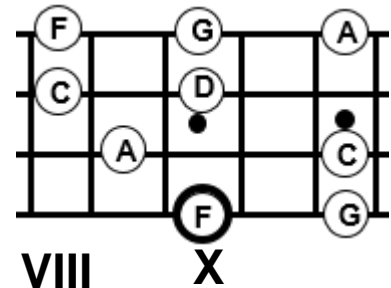

Finally, play the paired notes up to fret XII where you bar it and play the F shape F again, this time with a bar. Take another look at the shapes and locations Find the shapes and scales on the diagram below by finding the root – 8<sup>th</sup> fret 1<sup>st</sup> string for A shaped F. 5<sup>th</sup> fret of 2<sup>nd</sup> string for C & D and 1<sup>st</sup> fret 2<sup>nd</sup> string for F shape F.

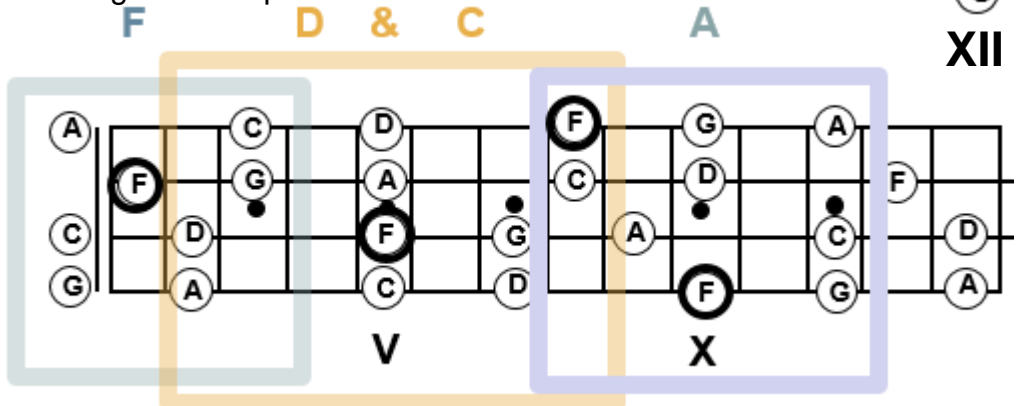
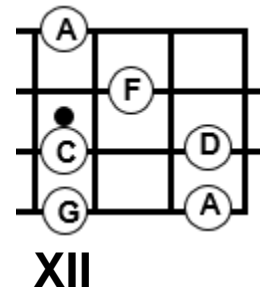

# Ukulele FDCA as a guide to soloing – key of D

## Pentatonic scale and the major chord shapes F, D, C & A

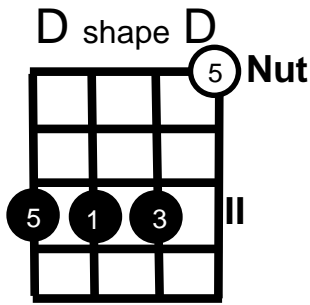

Play the **D major chord** at the nut and 2<sup>nd</sup> fret - familiarize yourself with the note positions – the D shape has the root on the 3<sup>rd</sup> string. Use the 3<sup>rd</sup> string as a guide for **D shape D**. Some root landmarks **D** is found on the 1<sup>st</sup> string fret 5, the 3<sup>rd</sup> string fret 2, the 4<sup>th</sup> string fret 6 and finally 2<sup>nd</sup> string fret 10

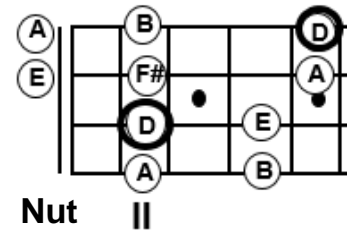

The 1,2 3 5 and 7 notes of the major scale form an **D major pentatonic scale [above]**. See the fretboard map on the right – the image is the fretboard viewed from the side as if you are looking down on the uke fretboard. D pentatonic scale= **D, E, F#, A, B and D**

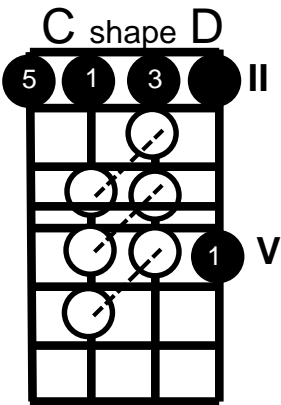

Bar the 2<sup>nd</sup> fret with your index finger and play the **C shape D** at the 2<sup>nd</sup> fret 2225. Then, play the pentatonic scale. You may already be familiar with such a pattern as a “blues box.” Play the opening notes of “*My Girl*”, in D, starting on the root on the 3<sup>rd</sup> string, 2<sup>nd</sup> fret.

Use the passing chords to find the **A shape D** at fret **V** and play it. Then, keep your ring finger barring the 5<sup>th</sup> fret and play the pentatonic scale at 5<sup>th</sup> and 9<sup>th</sup> frets. This shape lays out the major chord in sequence: 1, 3, 5, 1. Start on the A and find the first few notes of the *Star Spangled Banner* in D.

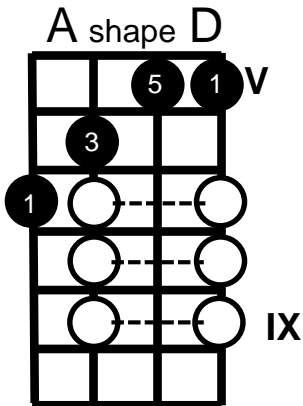
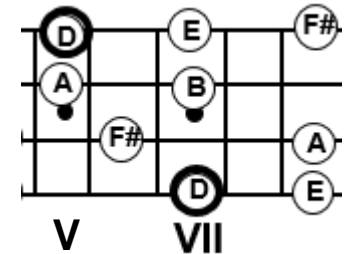

Then, play the paired notes up to fret **IX** where you bar it and play the **F shape D**. Take another look at the shapes and locations Find the shapes and scales on the diagram below by finding the root – 10<sup>th</sup> fret 1<sup>st</sup> string. Then, play *Swing Low Sweet Chariot* and find the melody on the pentatonic scale. Begin on the F# on 9<sup>th</sup> fret, 1<sup>st</sup> string.

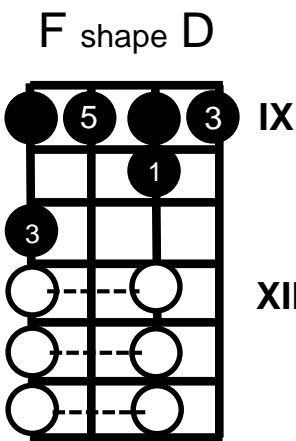
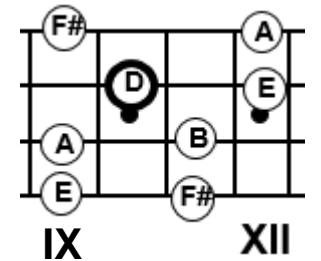

Use the passing chords to find the **D shape D**– finger the A at the 12<sup>th</sup> fret and bar the 2<sup>nd</sup> thru 4<sup>th</sup> strings at the 14<sup>th</sup> fret and play a **D shape D** at frets 12 and 14. Then play the D major pentatonic scale beginning on D 14<sup>th</sup> fret and 11<sup>th</sup> and fret.

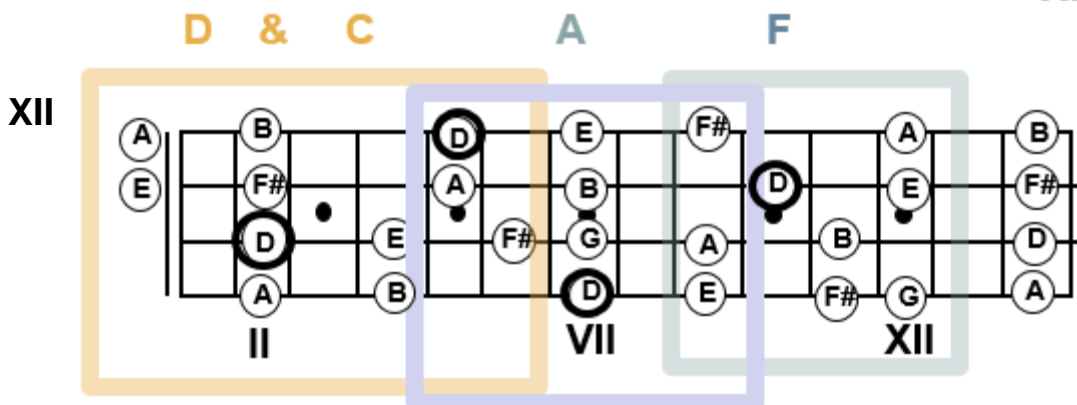
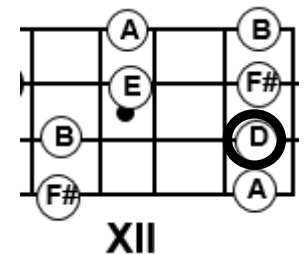

# Ukulele FDCA as a guide to soloing – key of C

## Pentatonic scale and the major chord shapes F, D, C & A

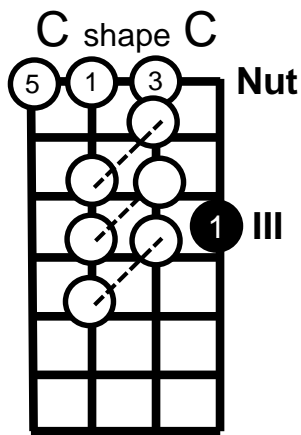

Play the **C major chord** at the nut and familiarize yourself with the note positions – the C shape has the root on the 1<sup>st</sup> and 3<sup>rd</sup> strings. Use the 1<sup>st</sup> string as a guide for **C shape C**.

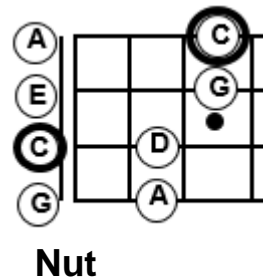

The 1, 2, 3, 5 and 7 notes of the major scale form an **C major pentatonic scale [above]**. See the fretboard map on the right – the image is the fretboard viewed from the side as if you are looking down on it. Play *Swing Low Sweet Chariot* a – start on open 2<sup>nd</sup> string E. Then find the melody on the C pentatonic scale. C, D, E, G and A.

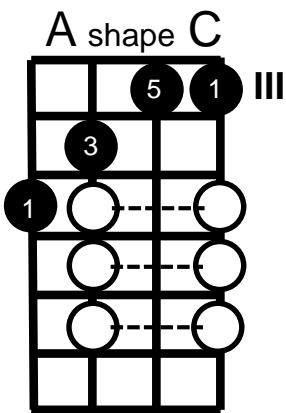

Use the passing chords to find 3<sup>rd</sup> fret – play **A shape C** at fret III. Remember that it is 1 3 5 1 notes. Then play the A major pentatonic scale beginning on C 5<sup>th</sup> fret 4<sup>th</sup> string. Then play *The Star Spangle Banner* and find the melody on the pentatonic scale. Begin on the G on 2<sup>nd</sup> fret, 2<sup>nd</sup> string.

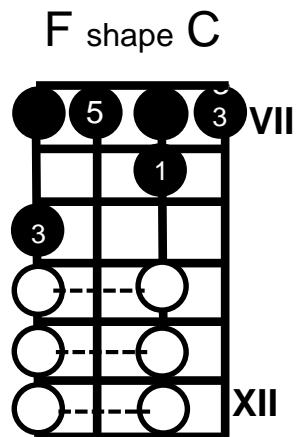
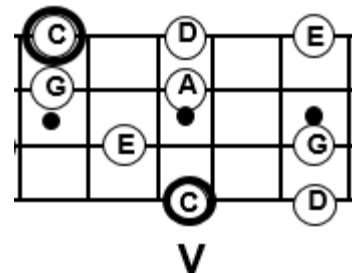

Use the passing chords to find the **F shape C** – bar the 7<sup>th</sup> fret and play an **F shape A**. Then play the C major pentatonic scale beginning on A 8<sup>th</sup> fret 2<sup>nd</sup> string. Then play *Swing Low Sweet Chariot* and find the melody on the pentatonic scale. Begin on the E on the 7<sup>th</sup> fret, 1<sup>st</sup> string.

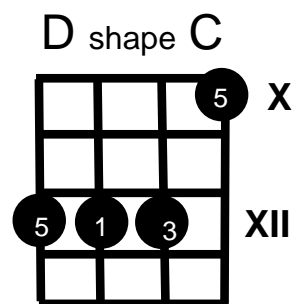
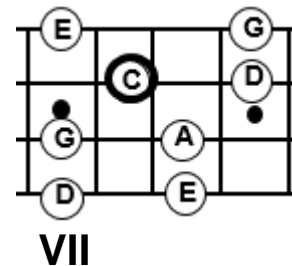

Finally, play the paired notes on strings 2 and 4 up to **fret XII** where you bar the 2<sup>nd</sup>, 3<sup>rd</sup> and 4<sup>th</sup> strings with your ring finger and play the **D shape C**. Find the shapes and scales on the diagram below by finding the **root** – 12<sup>th</sup> fret 3<sup>rd</sup> string C (as at the nut)

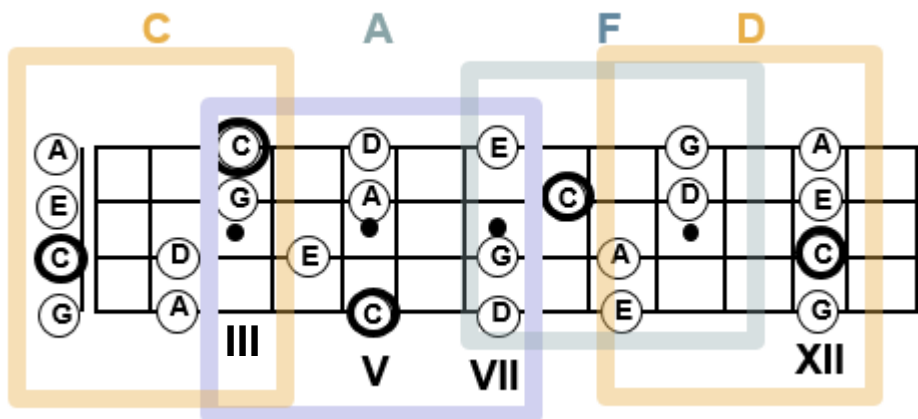
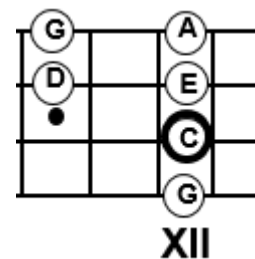

# Ukulele FDCA as a guide to soloing – key of A

## Pentatonic scale and the major chord shapes F, D, C & A

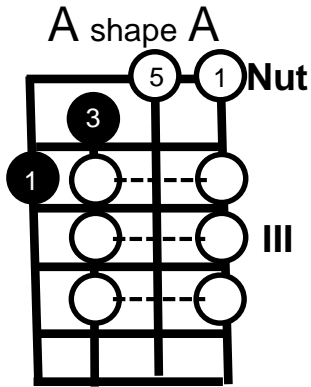

Play the **A major chord** at the nut and familiarize yourself with the note positions – the A shape has the root on the 1<sup>st</sup> and 4<sup>th</sup> strings. {1, 3, 5, 1} Use the 4<sup>th</sup> string as a guide for an **A shape A**. Other **A's** 2<sup>nd</sup> string 5<sup>th</sup> fret, 3<sup>rd</sup> string 9<sup>th</sup> fret.

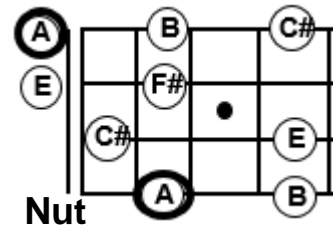

The 1,2 3 5 and 7 notes of the major scale form an **A major pentatonic scale** above. **Notes A, B, C#, E, F#, A**. See the fretboard map on the right – the image is the fretboard viewed from the side as if you are looking down on it. Play the *Star Spangled Banner* finding the melody on the pentatonic scale., beginning on open 2<sup>nd</sup> string

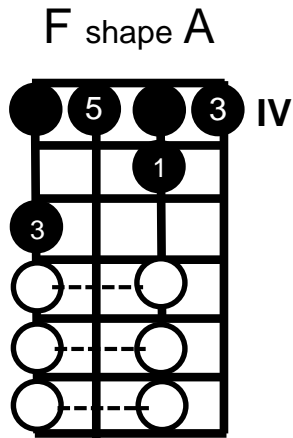

Use the passing chords to find the F shape A – bar the 4<sup>th</sup> fret and play a **F shape A at frets V and VII**.. Then play the A major pentatonic scale beginning on A 5<sup>th</sup> fret 2<sup>nd</sup> string. Then play *Swing Low Sweet Chariot* and find the melody on the pentatonic scale. Begin on the C# on 4<sup>th</sup> fret, 1<sup>st</sup> string.

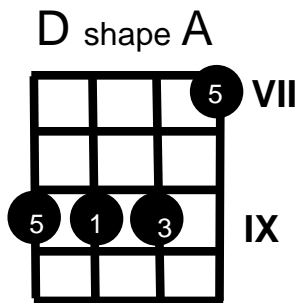
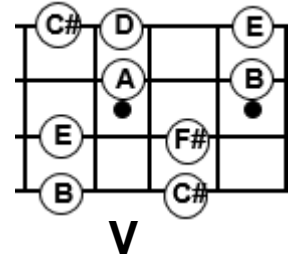

Use the passing chords to find the **D shape A at frets VII and IX** and play it. Then keep your ring finger barring the 9<sup>th</sup> fret and play the pentatonic scale at 7<sup>th</sup> and 9<sup>th</sup>. This scale can easily be adapted to the blues or rock and roll. Find the root on the 3<sup>rd</sup> string Use this A to play the melody for *Tennessee Waltz*. – next note B - 7<sup>th</sup>

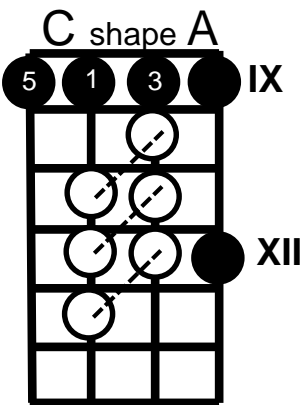
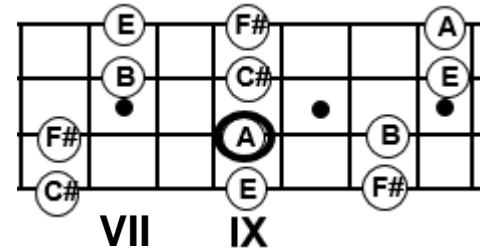

Play the **C shape A at fret IX**, and bar the 9<sup>th</sup> fret with your index finger to play the pentatonic scale. You may already be familiar with such a pattern as a “blues box.” Play the opening notes of “*My Girl*”, starting on the root on the third string.

Finally, play the paired notes up to **fret XII** where you play the **A shape A** again. Now, review the shapes and locations for the key of A.

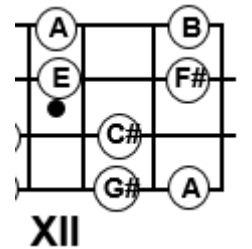

It is hard to overemphasize the importance of knowing for each of these keys, finding the “D & C” fret (D and C shape junction) of the pentatonic box – The root is on the 3<sup>rd</sup> string. At the nut for C, fret II for D, fret V for F, fret VIII for G and Fret IX for A, **C0 D2 F5 A9** **CDFA - 0 2 5 9**

