



Dead



SONARBOOK



SONGS

- | | | | |
|----|----------------------------------|----|-----------------------------|
| 1 | Around and Around | 27 | Iko Iko |
| 2 | Althea | 28 | In the Midnight Hour |
| 4 | Baby What You Want Me to Do | 29 | It Hurts Me Too |
| 5 | Beat it on Down the Line | 30 | It's All Over Now |
| 6 | Been All Around this World | 31 | Knockin' on Heaven's Door |
| 7 | Bertha | 32 | Mama Tried |
| 8 | Big Boss Man | 33 | Morning Dew |
| 9 | Big Railroad Blues | 34 | New Minglewood Blues |
| 10 | Big River | 35 | Next Time You See Me |
| 11 | Brokedown Palace | 36 | Not Fade Away |
| 12 | Box of Rain | 37 | Ripple |
| 14 | Casey Jones | 38 | Scarlet Begonias |
| 15 | Cold Rain and Snow | 39 | See See Rider |
| 16 | Dark Hollow | 40 | Sing Me Back Home |
| 17 | Deal | 41 | Sitting on Top of the World |
| 18 | Deep Elem Blues | 42 | Stealin' |
| 19 | Don't Ease Me In | 43 | Sugar Magnolia |
| 20 | Easy Wind | 44 | Sugaree |
| 21 | Fire on the Mountain | 45 | Tennessee Jed |
| 22 | Franklin's Tower | 46 | Truckin' |
| 23 | Friend of the Devil | 48 | Turn on Your Love Light |
| 24 | Going Down This Road Feeling Bad | 49 | Whiskey in the Jar |
| 25 | I Know You Rider | 50 | Uncle John's Band |
| 26 | I Need a Miracle | 52 | We Bid You Goodnight |

Compiled and arranged for uke by Spencer Gay – thanks to many sources
The Copyrighted songs provided free herein are for education and thus fall under Fair Use
This book is dedicated to Chris and Jo and not for sale

ALTHEA

GARCIA / HUNTER

Intro: Am G D G Am G D x2 or lick below

First note=A

Am G D G Am G D
 I told Althea I was feeling lost, lacking in some direction.
 Am G D G Am G D
 Althea told me upon scrutiny that my back might need protection.
 G Bm C G
 I told Althea that treachery was tearing me limb from limb.
 Bm D Am G D
 Althea told me better cool down boy, settle back, easy Jim.

Solo: Am G D G Am G D x2

Am G D G
 You may be Saturday's child, all alone,
 Am G D
 Moving with a tinge of grace.
 Am G D G
 You may be a clown in the burying ground,
 Am G D
 Or just another pretty face.
 G Bm C G
 You may be the fate of Ophelia, sleeping and perchance to dream.
 Bm D Am G D
 Honest to the point of recklessness, self-centered in the extreme.

Solo: Am G D G Am G D x2

Am G D G
 Ain't nobody messing with you, but you,
 Am G D
 Your friends are getting most concerned.
 Am G D G Am G D
 Loose with the truth, baby it's your fire, but baby don't get burned.
 G Bm C G
 When the smoke has cleared, she said, that's what she said to me.
 Bm D Am G D
 Gonna want a bed to lay your head and a little sympathy.

Solo: Am G D G Am G D x2

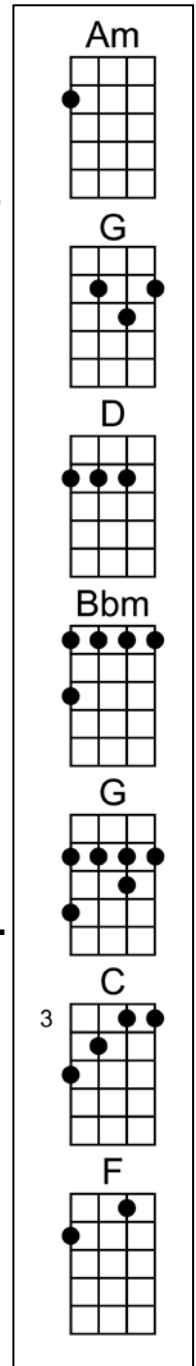

Bridge

C F D
There are things you can replace, and others you cannot.
C F
The time has come to weigh those things.
D Am G D
This space is getting hot, you know this space is getting hot.

Solo: Am G D G Am G D x2

Am G D G Am G D
I told Althea I'm a rogue inside, and I was born to be a bachelor.
Am G D G Am G D
Althea told me, okay, that's fine, so now I'm trying to catch her.

G Bm
Can't talk to you without talking to me,
C G
We're guilty of the same old thing.
Bm D
Been thinking a lot about less and less
Am G D
And forgetting the love we bring.

Solo: Am G D G Am G D x6

Intro

```
A |-----3---|-----3---|-----3---|-----|
E |-2-3-4-5---5-|-3-2h3-2---2-3-|-2-3-4-5---5-|-3-1h2---|
C |-----|-----2-----|-----|-----2-|
G |-----|-----|-----|-----|
```

Solo

```
A |-0-0---0-----|-----0-0---0-----|
E |-----3---3-3-2---2-3-|-----3---3-2---|
C |-----2-----|-----2-|
G |-----|-----|
```

BABY, WHAT YOU WANT ME TO DO

1959

JIMMY REED

A

You've got me runnin'. You've got me hidin'

A7

You've got me run, hide, hide, run, anyway you wanna

D7

A

Let it roll. Yeah, yeah, yeah

E7

You've got me doin' what you want me

D7

A (turnaround) E7

Baby, what you want me to do?

A

I'm goin' up. I'm goin' down.

A7

I'm goin' up, down, down, up, anyway you want me,

D7

A

Let it roll, yeah, yeah, yeah

E7

You've got me doin' what you want me

D7

A (turnaround) E7

Baby, what you want me to do?

Solo

A

You've got me peepin'. You've got me hidin'

A7

You've got me peep, hide, hide, peep, anyway you wanna

D7

A

Let it roll. Yeah, yeah, yeah

E7

You've got me doin' what you want me

D7

A (turnaround) E7

Baby, what you want me to do?

Repeat first or any of verses

First note=C

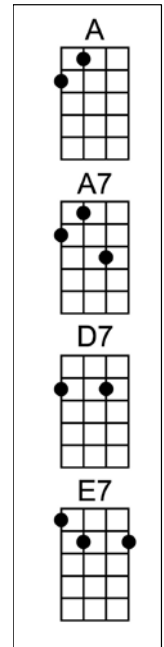

INTRO

E7

A SHUFFLE

D7 SHUFFLE

A 0-0--0-0--0-0---0- | -2-2--2-2--2-2--2-2 | -0-0--0-0--0-0--0-0- | -0-0--2-2--0-0--2-2

E 3-3--2-2--1-1---0- | -0-0--0-0--0-0--0-0- | -0-0--2-2--0-0--2-2- | -2-2--2-2--2-2--2-2

C 4-4--3-3--2-2-0h1- | -2-2--2-2--2-2--2-2 | -2-2--1-1--2-2--1-1- | -0-0--0-0--0-0--0-0

G-----0h2- | -1-1--1-1--1-1--1-1 | -1-1--2-2--1-1--2-2- | -2-2--2-2--2-2--2-2

You got me..

BEAT IT ON DOWN THE LINE

1961

JESSE FULLER

First note = C

Intro: F x5

Strum=D DU UD

Well this job I've got is just a little too hard,

Running out of money, Lord, I need more pay.

Gonna wake up in the morning Lord, gonna pack my bags,

I'm gonna beat it on down the line.

I'm goin' down the line (goin down the line)

Goin' down the line (goin down the line)

Goin' down the line (goin down the line)

Beat it on down the line.

Yes I'll be waiting at the station Lord, when that train pulls on by,

I'm going back where I belong. I'm going back to that same old used-to-be,

Down in Joe Brown's coal mine.

Coal mine, coal mine, coal mine, coal mine.

Coal mine, coal mine, coal mine, coal mine.

Coal mine, coal mine, coal mine, coal mine.

Down in Joe Brown's coal mine.

Down in Joe Brown's coal mine.

HARP BREAK

Yeah, I'm goin' back to that shack way across that railroad track,

Uh huh, that's where I think I belong.

Got a sweet woman, Lord, she's waitin' there for me,

And that's where I'm gonna make my happy home.

Happy home, happy home, happy home, happy home.

Happy home, happy home, happy home, happy home.

Happy home, happy home, happy home, happy home.

That's where I'm gonna make my happy home.

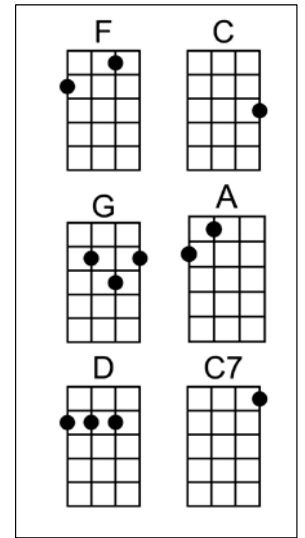

	F	C
	G	C C7
	F	C A

BEEN ALL AROUND THIS WORLD

UNKNOWN

Intro: below

Strum=D DU UD

First note= Eb

C
Upon the Blue Ridge Mountains, there I'll take my stand.

C C7 F C
Upon the Blue Ridge Mountains, there I'll take my stand.

F C
A rifle on my shoulder six shooter in my hand;
C G C
Lord, Lord, I've been all around this world.

C
Lulu, my Lulu come and open the door.

C C7 F C
Lulu, my Lulu come and open the door.

F C
Before I have to walk on in with my old forty-four.
C G C
Lord, Lord, I've been all around this world.

C
Mama and Papa, little sister makes three.

C C7 F C
Mama and Papa, little sister makes three.

F C
They're comin' in the mornin'; that's the last you'll see of me.
C G C
Lord, Lord, I've been all around this world.

C
Hang me, oh, hang me, so I'll be dead and gone.

C C7 F C
Hang me, oh, hang me, so I'll be dead and gone.

F C
I wouldn't mind your hangin' boys, but you wait in jail so long.
C G C
Lord, Lord, I've been all around this world.

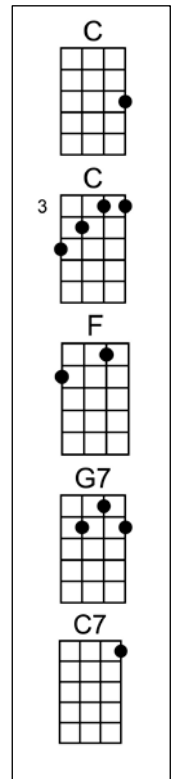

Repeat first verse

INTRO

A	-----		-----		-3-5-7-5-3-5-3-----3-		---3-3-----	
E	---3-5-3-----		-----3-5-3-----		-----5-3-5--		3-5---5-3-	
C	-3-4-----3-4--		-3-4-----3-4--		-----		-----	
G	-----5		-----5		-----		-----	

A	-----3-5-3-		-----3-----		-----	
E	-3-5-5--3-5-3-----		5-3-5-3--5-3-----		-----3-5-3-----	
C	-----		-----3-4--		---3-4-----3-4--	
G	-----		-----5		-0-0-----5	

BERTHA

GARCIA/HUNTER

Intro: below C F C C F C Strum=D DU UDU
F C F C

First note=C

I had a hard run, runnin' from your window.

F C F C C F C
I was all night running, running, lord I wonder if you care,

F C F C C F C
I had a run in, run around, and run down.

F C F C C F C
Run around the corner, corner, Lord run smack into a tree.

F F# G Dm C F G
I had to move, really had to move,

F C G F
That's why if you please, I am on my bended knees,
Dm F C F C C F C
Bertha don't you come around here anymore.

Dressed myself in green, I went down unto the sea.
Try to see what's goin' down, try to read between the lines.
I had a feelin' I was fallin', fallin', fallin', I turned around to see,
Heard a voice al callin', Lord you was commin' after me.

I had to move, really had to move,
That's why if you please, I am on my bended knees,
Bertha don't you come around here anymore.

Ran into a rainstorm, I ducked back into a bar door.
It's all night pourin', pourin', pourin', Lord but not a drop on me.
Test me, test me, Test me, test me, test me, why don't you arrest me?
Throw me in to the jailhouse, Lord until the sun goes down, ('till it goes down.)

I had to move, really had to move,
That's why if you please, I am on my bended knees,
Bertha don't you come around here anymore. Anymore Anymore

At the end of lines and intro
C F C = C FC FC
D DUDD UD UD

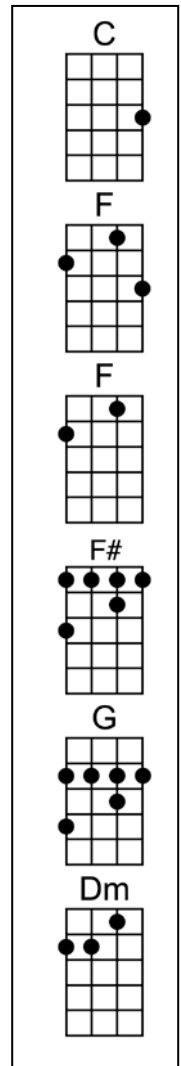

BIG BOSS MAN

1960

LUTHER DIXON & AL SMITH

First note=E

A A7
 Big boss man, can't you hear me when I call?
 D A
 Big boss man, can't you hear me when I call?
 E7 D7 A E7
 You ain't so big, you just tall, that's just about all.

A
 You got me working boss man, a-workin' around the clock,
 A A7
 I want a little drink of water, you sure won't let me stop.
 D A
 Big boss man, can't you hear me when I call?
 E7 D7 A E7
 You ain't so big, you just tall, that's just about all.

Solo – harp or use A blues scale at the nut

A
 I'm gonna get me a boss man, one gonna treat me right,
 A A7
 I work hard in the daytime, sure get drunk at night.
 D A
 Big boss man, can't you hear me when I call?
 E7 D7 A
 You ain't so big, you just tall, that's just about all.

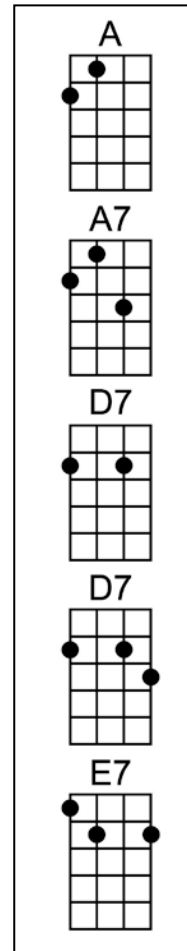

INTRO

A	-----4-----4-----	-----4-----4-----0-	--0-2-0--	-----0-	2-2-2---
E	-----	-----	2---	3-3-2-2-1-1-0-	0-0-0---
C	-2h4---4---4---4-2--	2h4---4---4---4---	-----1--	4-4-3-3-2-2-1-	2-2-2---
G	-----	-----	-----2--	-----2-	1-1-1---

A shuffle	D shuffle	E7 lick
A -0-0--0-0--0-0--0-0-	-0-0--2-2--3-3--2-2	-2-----3-0-----
E -0-0--2-2--3-3--2-2-	-2-2--2-2--2-2--2-2	-0-3b4-0--0--2---3-0-0-----
C -2-2--1-1--2-2--1-1-	-0-0--0-0--0-0--0-0	-2-----2---0-----2-0--
G -1-1--2-2--1-1--2-2-	-2-2--2-2--2-2--2-2	-1-----2-----2-----2

Turnaround	Alternative turnaround
A -4---0---0-2--0-	-4----- ----- ---5
E -3---2-2--1-1--0-	---5---5-7-5- ----- ---4
C -4---3-3--2-2--1-	-----6----- 7-7-6-6-5-5-4- ---4
G -----2-	----- ----- 4-4

BIG RAILROAD BLUES

NOAH LEWIS

Intro: below

Well my mama told me, my papa told me too,
 Now my mama told me, papa told me too,
 Well I shouldn't be here tryin' to sing these railroad blues.

Wish I had a'listened, oh-oh to what mama said,
 Wish I had a'listened, oh-oh to what mama said,
 Well I wouldn't be here tryin' to sleep in this cold iron bed.

Solo

Well I went to the depot, I never got there on time,
 Went down to the depot, never got there on time.
 Well my train done left, he's a rollin' down the line.

Mister jailer go away now, don't tell me no lies,
 Mister jailer go away, don't tell me no lies,
 When the train's going down, she's rollin' down the line.

Solo

Well my mama told me, my papa told me too,
 Now my mama told me, papa told me too,
 Well I shouldn't be here tryin' to sing these railroad blues

First note=E

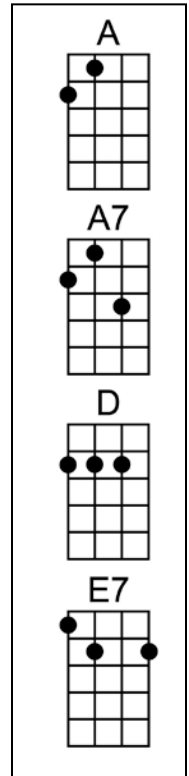

INTRO	End of line-also location of beginning of solo
A -----0-0-----	-9-7----- ----- ...
E -----0-0-2-----3-2-----	-----8-7--- -----9-
C -1-1-----0-h1--	-----9- -----b11-11-9-9---
G -----2	----- -9-11-----

BIG RIVER

Intro: A x2

Strum= D DU UD

Chorus

A
Well I taught that weeping willow how to cry cry cry,
B E7
Taught the clouds how to cover up a clear blue sky.
A D
Tears I cried for that woman are gonna flood you big river,
A E7 A
And I'm a gonna sit right here until I die.

A
I met her accidentally in St. Paul, Minnesota,
A B E7
She tore me up everything I heard her drawl, Southern drawl.
A D
Well I heard my dream went back downstream, cavortin' in Davenport,
A E7 A
And I followed you big river when you called.

Chorus

Solo

A
Well I followed her down to St. Louie, later on down the river,
A B E7
Trader said she's been here, but she's gone, boy, she's gone.
A D
Well I found her trail in Memphis, but she just walked up the block,
A E7 A
She raised a few eyebrows and she went on down alone.

Solo

A
Well I've gotten on down to Baton Rouge, River Queen roll on,
B E7
Take that woman down to New Orleans, New Orleans.
A D
Go on, I've had enough, dump my blues on down to the gulf,
A E7 A
She loves you big river more than me.

Repeat Chorus tag last line

JOHNNY CASH

First Note=D

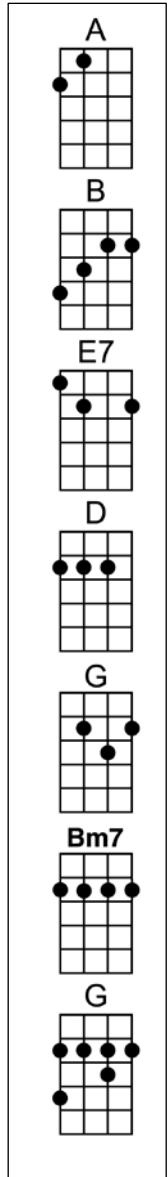

Solo

A	-----0--0--0----- -----0--0-2-3-2-0----- 0-3-0-3-3-0-3-5-3-0--0- -0-----
E	0-2--2--2--2----- 0-2--2----- -----3----- ---3-0-----
C	-----0-h1--- -----0-h1-- ----- -----2-0--
G	-----2- -----2- -----2- -----2-

10

BROKEDOWN PALACE

GARCIA/HUNTER

Intro: G Am G Am

Strum=D UD UD UD D

First note=B

G Am Bb F C
 Fare you well, my honey, fare you well my only true one.
 G Dm Bb C F
 All the birds that were singing are flown, except you alone.

F Bb
 Going to leave this brokedown palace,
 F Dm Bb F
 On my hands and my knees, I will roll, roll, roll.
 F Am Bb F
 Make myself a bed in the waterside,
 F G Bb F
 In my time, In my time, I will roll, roll roll.

F A Bb F G
 In a bed, in a bed, by the waterside I will lay my head.
 F G Bb F
 Listen to the river sing sweet songs, to rock my soul.

F Bb
 River going to take me, sing sweet and sleepy,
 F Dm Bb F
 Sing me sweet and sleepy all the way back home.
 F Am Bb
 It's a far gone lullaby, sung many years ago.
 F G Bb F
 Mama, mama many worlds I've come since I first left home.

F A Bb F G
 Goin' home, goin' home, by the waterside I will rest my bones,
 F G Bb F
 Listen to the river sing sweet songs, to rock my soul.

F Bb
 Going to plant a weeping willow,
 F Dm Bb F
 On the bank's green edge it will grow, grow, grow.
 F Am Bb
 Sing a lullaby beside the water,
 F G Bb F
 Lovers come and go, the river roll, roll, roll.

F A Bb F G
 Fare you well, fare you well, I love you more than words can tell,
 F G Bb F
 Listen to the river sing sweet songs, to rock my soul.

F Bb F G Bb F
 Doo do doo, do da do, doo-oo, doo, do doo, da doo da doo
 F Bb F G Bb F F G Bb F
 Doo do doo, do da do, doo-oo, doo, do doo, da doo da doo Do do doo, do doo, da doo da doo

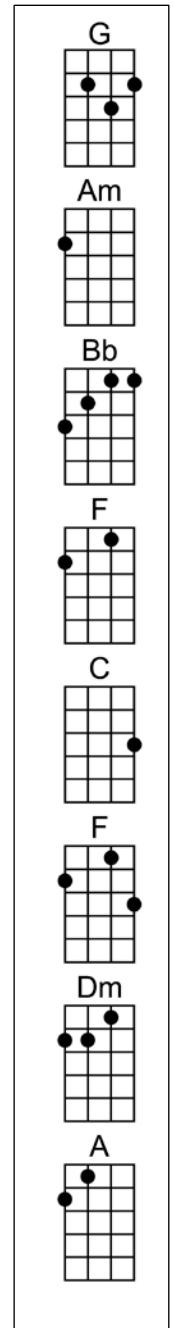

BOX OF RAIN

HUNTER/LESH

Intro: A Dsus4 A Asus4 x2 Strum= DDD D D UUD

D Am Em C G
 Look out of any window, any morning, any evening, any day.
 D Am Em
 Maybe the sun is shining, birds are winging,
 G A
 No rain is falling from a heavy sky.

D G Am Em D
 What do you want me to do, to do for you to see you through?
 C D Am G
 For this is all a dream we dreamed one afternoon, long ago.

D Am Em
 Walk out of any doorway, feel your way,
 C G
 Feel your way like the day before.

D Am
 Maybe you'll find direction,
 Em G A
 Around some corner where it's been waiting to meet you.

D G
 What do you want me to do,
 Am Em D
 To watch for you while you are sleeping?
 Am C G D
 Then please don't be surprised when you find me dreaming too.

D Am Em C
 Look into any eyes you find by you,
 G

D Am
 You can see clear to another day,
 D Am
 Maybe been seen before,
 Em G A
 Through other eyes on other days while going home.

D G Am Em D
 What do you want me to do, to do for you to see you through?
 C Em D G
 It's all a dream we dreamed one afternoon, long ago.

First Note=D

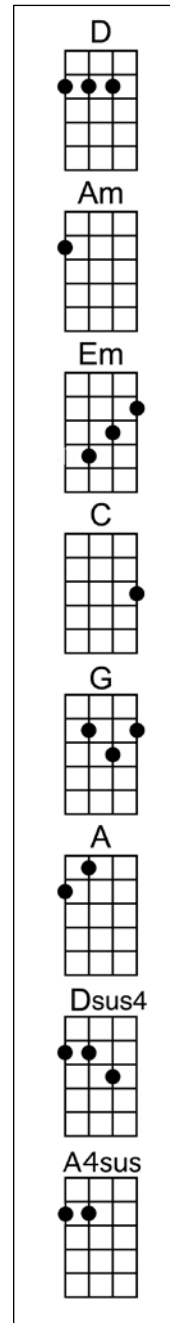

D Am
 Walk into splintered sunlight,
 Em C G
 Inch your way through dead dreams to another land.
 D Am
 Maybe you're tired and broken,
 Em G
 Your tongue is twisted with words half spoken and thoughts unclear

D G Am Em D
 What do you want me to do, to do for you to see you through?
 Am C G D
 A box of rain will ease the pain, and love will see you through.

G Am Em
 Just a box of rain, wind and water,
 C A D
 Believe it if you need it, if you don't, just pass it on
 G Am Em
 Sun and shower, wind and rain,
 C D Em A
 In and out the window like a moth before a flame.

A D Em G D
 And it's just a box of rain, I don't know who put it there,
 D Bm G A
 Believe it if you need it, or leave it if you dare.
 A D Em G D
 And it's just a box of rain, or a ribbon for your hair;
 Em
 Such a long long time to be gone,
 G D D C G D Asus4
 And a short time to be there.

CASEY JONES

Intro below

Chorus

C F
 Drivin' that train, high on cocaine,
 C
 Casey Jones you'd better watch your speed
 F
 Trouble ahead, trouble behind
 C
 And you know that notion just crossed my mind.

C D
 This old engine makes it on time
 F G
 Leaves central station at a quarter to nine
 C D
 Hits River Junction at seventeen to,
 F E7 Am G7
 At a quarter to ten you know it's travelin' again

C C# D
 Trouble ahead, a lady in red
 F G
 Take my advice you'd be better off dead
 C F
 Switch man sleepin', train a hundred and two
 F E7 Am G7
 Is on the wrong track and headed for you

Chorus -- Solo - follow verse then chorus chords

C D
 Trouble with you is the trouble with me,
 F G
 Got two good eyes but we still don't see
 C F
 Come 'round the bend you know it's the end
 F E7 Am G7
 'Cause the fireman screams and the engine just gleams

Repeat chorus

C Bb F
 Drivin' that train, high on cocaine,
 C
 Casey Jones you'd better watch your speed
 Bb F
 Trouble ahead, trouble behind
 C
 And you know that notion just crossed my mind.
 A7 D7 G7 C
 And you know that notion just crossed my mind.

GARCIA/HUNTER

Strum=DUDU UD

First note=G

Intro	F	C
A	-3-0-----0-0-3-	
E	-----3-0-----1-1-0-	
C	-----2-0--0-0-0-	
G	-----2-2-0-	

DARK HOLLOW

BILL BROWNING

Walkup below

Strum=D DU UD or dD dD dD dD

First note=B

G D G
I'd rather be in some dark hollow

G C G
Where the sun don't ever shine

G G7 C
Than to be home alone knowing that you're gone

G D G
Would cause me to lose my mind

G D G
So blow your whistle freight train

G C G
Carry me further on down the track

G G7 C C7
I'm going away, I'm leaving today

G D G
I'm going, but I ain't coming back

G D G
I'd rather be in some dark hollow

G C G
Where the sun don't ever shine

G G7 C
Then to be in some big city,

G D G
In a small room, with you on my mind

Solo

G D G
So blow your whistle freight train

G C G
Carry me further on down the track

G G7 C C7
I'm going away, I'm leaving today

G D G
I'm going, but I ain't coming back

G D G
I'd rather be in some dark hollow

G C G
Where the sun don't ever shine

G G7 C
Then to see you another mans darlin',

G D G
And to know that you'll never be mine

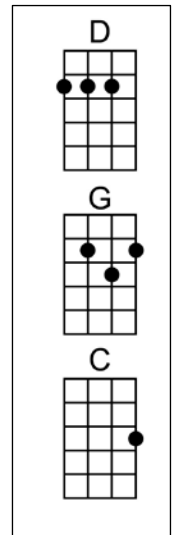

Walkup to G

```
A |-----2-|
E |-----3-|
C |---0-1-2-2-|
G |-4-----|
```

Solo

```
A |-----|-----|
E |-----|---5-7-5-----|
C |-----4-----7-|-7-----7-4---|
G |-4-5-6-7---7-7-7---|-----7-|

A |-----5-----|-----|
E |---5-7---7-5-|-----|
C |-7-----|---7-7-4-7-|-4-----|
G |-----|-----|---7-4-7-2/4-0-|
```

DEAL

GARCIA/HUNTER

Intro below

Strum=D DU UD but varies

First note=B

G B7
 Since it costs a lot to win,
 Em D C7 Gdim7
 And even more to lose,
 G G F# F E
 You and me bound to spend some time
 A C
 Wond'rin' what to choose.
 G B7
 Goes to show, you don't ever know,
 Em D C7 Gdim7
 Watch each card you play and play it slow,
 G F C
 Wait until that deal come round,
 G F C G
 Don't you let that deal go down, no, no.

I been gamblin' hereabouts
 For ten good solid years,
 If I told you 'bout all that went down
 It would burn off both of your ears.
 Goes to show you don't ever know
 Watch each card you play and play it slow,
 Wait until that deal come round,
 Don't you let that deal go down, no, no.

Since you poured the wine for me
 And tightened up my shoes,
 I hate to leave you sittin' there,
 Composin' lonesome blues.
 Goes to show you don't ever know
 Watch each card you play and play it slow,
 Wait until that deal come round,
 Don't you let that deal go down.

G F C G F C G
 Wait until that deal come round, Don't you let that deal go down,
 Wait until that deal come round, Don't you let that deal go down,
 Don't you let that deal go down, Don't you let that deal go down.

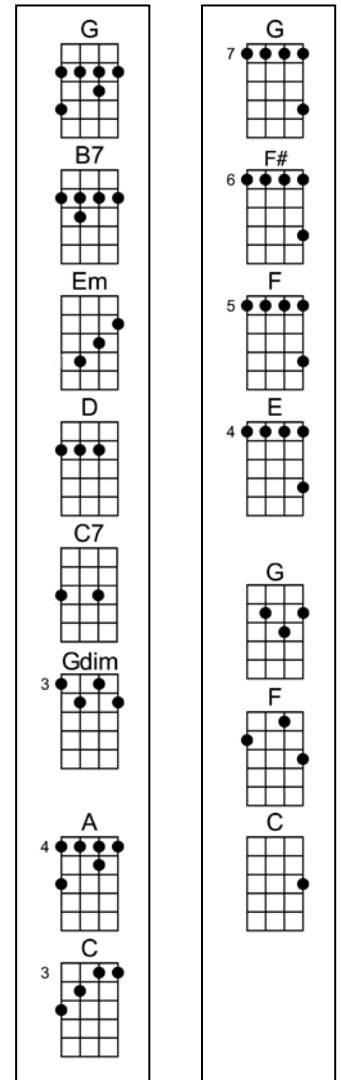

INTRO	G	F	C
A	-10---10---10-8---8--7---7-		
E	---7---7-----5---8-8---		
C	-----		
G	-----		

DEEP ELEM BLUES

TRADITIONAL

Intro: intro lick below or harp

Strum=dD

First note = G

G
 Once I knew a preacher,
 Preached the Bible through and through,
 He went down to Deep Elem,
 Now his preachin' days are through.

Chorus
C7
 Oh sweet mama

G
 Your daddy's got them Deep Elem blues.

D7
 Oh sweet mama

C7 **G**
 Your daddy's got them Deep Elem blues.

G
 Once I had a girlfriend.
 She meant the world to me.
 She went down to Deep Elem,
 Now she ain't what she used to be.

Chorus

G
 When you go down to Deep Elem,
 Put your money in your socks.
 'Cause them women in Deep Elem
 Will sure put you on the rocks.

Harp break, then Chorus

G
 If you go down to Deep Elem
 To have a little fun,
 Have your ten dollars ready
 When the policeman comes.

Chorus

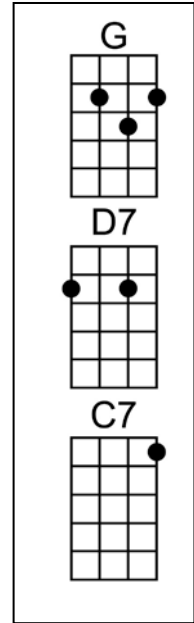

Intro	
	G
A-----	2--
E-----	3--3--
C-----	2-4-2----2--
G--0-3h4-	-----

DON'T EASE ME IN

TRADITIONAL

Intro D G D G D

Strum= UDU UDU

First note= D

Chorus

D
Don't ease, don't ease,

A
Don't ease me in.

A G A G
I've been all night long comin' home,

A D G D G D
Don't ease me in.

D A
I was standin' on the corner, talkin' to Miss Brown

D
I turned around sweet mama, she was way across town

Chorus

D A
So I'm walkin' down the street with a dollar in my hand

D
I've been lookin' for a woman, sweet mama, ain't got no man.

Chorus

D A
The girl I love, she's sweet and true,

D
And the dress she wears, sweet mama, it's pink and blue,

Chorus

D A
She brings me coffee, she brings me tea,

D
She brings me 'bout every damm thing but the jailhouse keys

Chorus

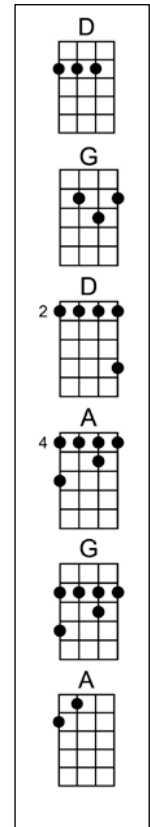

EASY WIND

Chorus

Strum=DD UUU DU DU

A7 E7 E7 E7 [*walkdown below]

Easy wind cross the Bayou today

A7

Cause there's a whole lotta women, mama,

E7

Out in red on the streets today.

B

And the river keeps a talkin',

A

C

E7

But you never heard a word it said.

E7

I been balling a shiny black steel jack-hammer,

A7

E7 A7

Been chippin' up rocks for the great highway

E7

I'll live five years if I take my time,

A7

7 A7

Ballin' that jack and a drinkin' my wine.

Chorus

E7

I been chippin' them rocks from dawn till doom,

A7

E7 A7

While my rider hide my bottle in the other room.

E7

Doctor say better stop ballin' that jack,

A7

E7 A7

If I live five years I gonna bust my back, yes I will.

Chorus then D Harp solo, uke solo over E7 A7 – blues box at fret VII

E7

Gotta find a woman be good to me

A7

E7 A7

Won't hide my liquor try to serve me tea,

E7

Cause I'm a stone jack baller and my heart is true

A7

E7 A7

And I'll give everything that I got to you, yes I will.

Chorus

HUNTER

First note=B

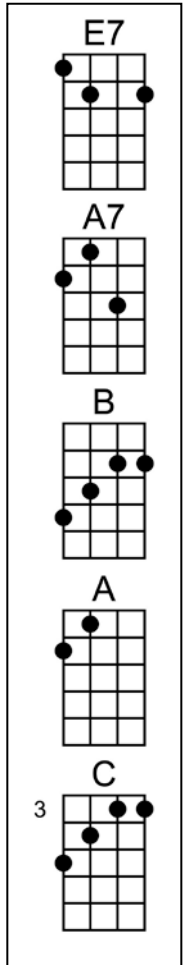

*End of line in Chorus

E7

A -7--7-----||

E -7--7--10-7-----||

C -8--8-----9-7---||

G -7--7-----9-||

FIRE ON THE MOUNTAIN

HART/HUNTER

Intro: B A x4

Strum= DxxxxDxxxx U

First note=A

B A
 Long distance runner, what you standin' there for?
 B A
 Get up, get up, get out of the door
 B A
 Your playin' cold music on the barroom floor
 B A
 Drowned in your laughter and dead to the core.
 B A
 There's a dragon with matches that's loose on the town
 B A
 Take a whole pail of water just to cool him down.

B A
 Fire! Fire on the mountain!

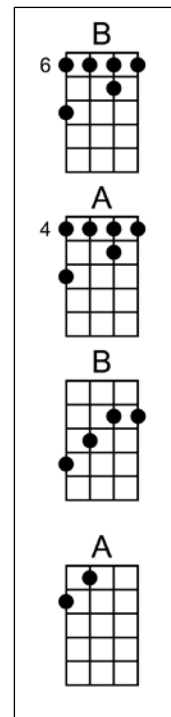

Almost ablaze still you don't feel the heat
 It takes all you got just to stay on the beat.
 You say it's a livin', we all gotta eat
 But you're here alone, there's no one to compete.
 If mercy's in bus'ness, I wish it for you
 More than just ashes when your dreams come true.

Fire! Fire on the mountain!

Solo

Solo	...
A	-----
E	-----8-7-6-
C	-7-7-6-7-----
G	-----

Long distance runner, what you holdin' out for?
 Caught in slow motion in a dash for the door.
 The flame from your stage has now spread to the floor
 You gave all you had, Why you wanna give more?
 The more that you give, the more it will take
 Till the thin line beyond which you really can't fake.

Fire! Fire on the mountain!

FRANKLIN'S TOWER

GARCIA/HUNTER/KRUETZMANN

Intro A G D G

Strum= D xxxx DDD

First note=A

A G D G
In another times forgotten space
A G D G
Your eyes looked from your mother's face
A G D G
Wildflower seed on the sand and stone
A G D G
May the four winds blow you safely home

A G D G
Roll away the dew

I'll tell you where the four winds dwell
In Franklin's tower there hangs a bell
It can ring, turn night to day
It can ring like fire if you lose your way

Roll away the dew

God save the child that rings that bell
May have one good ring baby, you can't tell
One watch by night, one watch by day
If you get confused, listen to the music play

Solo over verse

Some come to laugh their past away
Some come to make it just one more day
Whichever way your pleasure tends
If you plant ice, you're gonna harvest wind

Roll away the dew

In Franklin's tower the four winds sleep
Like four lean hounds, the lighthouse keep
Wildflower seed on the sand and wind
May the four winds blow you home again

Roll away the dew

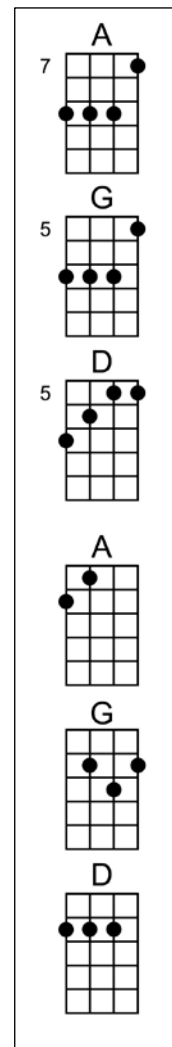

FRIEND OF THE DEVIL

GARCIA/HUNTER/DAWSON

Intro D 4 bars

Strum= D DU UD

First note=D

G C
I lit out from Reno, I was trailed by twenty hounds
G C
Didn't get to sleep that night 'till the morning came around.

Chorus

D Am
Set out runnin' but I take my time, a friend of the devil is a friend of mine
D Am C D
If I get home before daylight, I just might get some sleep tonight.

G C
Ran into the devil, babe, he loaned me twenty bills
G C
I spent the night in Utah In a cave up in the hills.

Chorus

G C
I ran down to the levee but the devil caught me there
G C
He took my twenty dollar bill and vanished in the air.

Chorus

D
Got two reasons why I cry away each lonely night,
C C C#
The first one's named Sweet Anne Marie and she's my hearts delight.
D
The second one is prison, babe, the sheriff's on my trail,
Am C D
And if he catches up with me, I'll spend my life in jail.

G C
Got a wife in Chino, babe, and one in Cherokee
G C
The first one says she's got my child, but it don't look like me.

Chorus

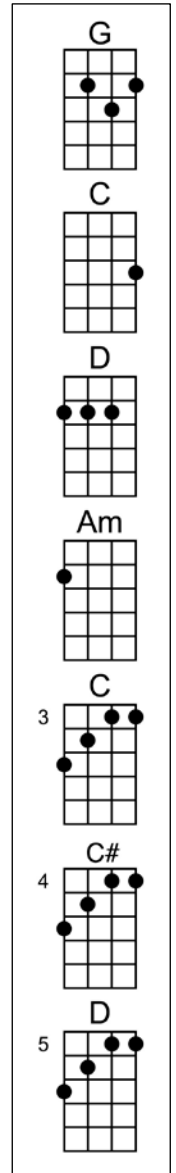

GOING DOWN THIS ROAD FEELING BAD

UNKNOWN

First note= F#

Chorus

D **D7**
 I'm going down this road feeling bad,
G **D**
 I'm going down this road feeling bad,
G **D**
 I'm going down this road feeling bad, Lord Lord,
A **A7** **D**
 And I ain't gonna be treated this a- way.

I'm down in that jail on my knees,
 I'm down in that jail on my knees,
 I'm down in that jail on my knees,
 And I ain't gonna be treated this a- way.

They feed me on cornbread and beans
 They feed me on cornbread and beans
 They feed me on cornbread and beans
 And I ain't gonna be treated this a- way.

'Cause your two dollar shoes hurt my feet,
 'Cause your two dollar shoes hurt my feet,
 'Cause your two dollar shoes hurt my feet,
 And I ain't gonna be treated this a- way.

Solo

I'm going where the weather suits my clothes,
 I'm going where the weather suits my clothes,
 I'm going where the weather suits my clothes,
 And I ain't gonna be treated this a- way.

I'm going down this road feeling bad,
 I'm going down this road feeling bad,
 I'm going down this road feeling bad, Lord Lord,
 And I ain't gonna be treated this a- way.

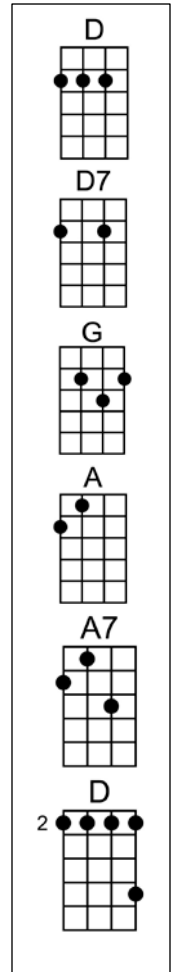

Chorus

Intro	A7	D	Solo beginning
A	-----0-0---0-----0-		-----0-0-2-0-0---
E	-2-3--3---3---1-2---2-		-2-3--2-----2-
C	-----1-----2-2-		-----2-----
G	-----2-----2-		-----2-----

I KNOW YOU RIDER

TRADITIONAL

Intro D 4 bars

Strum= D DU UD

First note=D

D C G D
I know you rider, gonna miss me when I'm gone;
D C G D
I know you rider, gonna miss me when I'm gone;
F C F C Em D
Gonna miss your baby, from rollin' in your arms.

D C G D
Lay down last night, Lord I could not take my rest;
D C G D
Lay down last night, Lord I could not take my rest;
F C F C Em D
My mind was wanderin' like the wild geese in the west.

Solo

D C G D
The sun will shine in my back door someday;
D C G D
The sun will shine in my back door someday;
F C F C Em D
March winds will blow all my troubles away.

D C G D
I wish I was a headlight, on a North bound train;
D C G D
I wish I was a headlight, on a North bound train;
F C F C Em D
I'd shine my light through the cool Colorado rain.

Solo

D C G D
I'd rather drink muddy water, sleep in a hollow log
D C G D
I'd rather drink muddy water, sleep in a hollow log
F C F C Em D
Then stay here in 'Frisco, be treated like a dog

D C G D
I know you rider, gonna miss me when I'm gone;
D C G D
I know you rider, gonna miss me when I'm gone;
F C F C Em D
Gonna miss your baby, from rollin' in your arms.
F C F C G D
Gonna miss your baby, from rollin' in your arms.

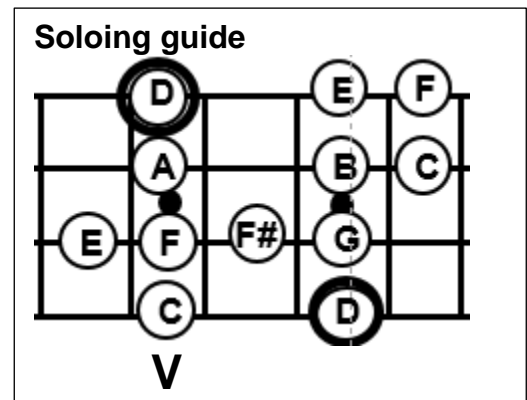
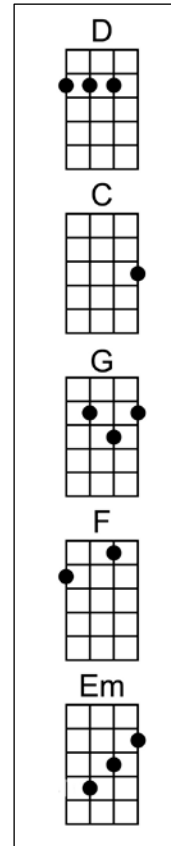

I NEED A MIRACLE

BARLOW, WEIR

Intro below x4

Strum=dD dD

First note=E

E7
 I need a woman 'bout twice my age,
 A lady of nobility, gentility and rage,
 Splendor in the dark, lightning on the draw,
 We'll go right through the book and break each and every law.

A E7
 I got a feeling and it won't go away, oh no.

B7
 Just one thing then I'll be okay,

E7
 I need a miracle every day.

E7
 I need a woman 'bout twice my height,
 Statuesque, raven-dressed, a goddess of the night.
 Her secret incantations, a candle burning blue,
 We'll consult the spirits, maybe they'll know what to do.

A E7
 And it's real and it won't go away, hey hey hey,

B7
 I can't get around and I can't run away,

E7
 I need a miracle every day.

Solo over verse and chorus

E7
 I need a woman 'bout twice my weight,
 A ton of fun who packs a gun with all her freight.
 Find her in the sideshow, leave her in L.A.,
 Ride her like a surfer riding on a tidal wave.

A E7
 And it's real, believe what I say, yeah.

B7
 Just one thing that I've got to say,

E7
 I need a miracle every day.

B7
 It takes dynamite to get me up,

E7
 Too much of everything is just enough.

B7 E7 G7
 One more thing I just got to say. I need a miracle every day. I need a miracle every day

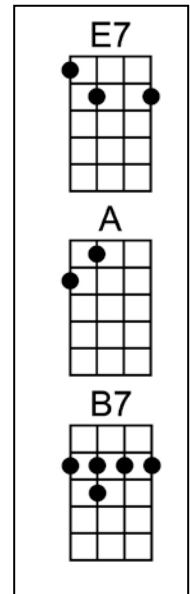

Intro	E7
A	-2-2-0-----2- -2-
E	-----3-0-0- -0-
C	-----2- -2-
G	-----1- -1-

IKO IKO

JOCKAMO JAMES CRAWFORD

Intro: D D A A A D

Strum= D DU UD DD

First note = A

Chorus

D A
Hey now, Hey now, Iko Iko ahnday
A D
Jocamo feena nay Jocamo feena nay

D A
My spy boy to your spy boy, sittin' on the bayou,
A D
My spy boy to your spy boy, I'm gonna set your tail on fire.

Chorus talkin' bout..

My Grandma to your Grandpa, sittin on' the bayou
My Grandma to your Grandpa, gonna fix your chicken wire.

Chorus

We goin' down, to Bedford town, Iko, Iko ahnday,
We're gonna tell 'em 'bout your messin' around, with Jocamo feena nay

Chorus

My marraine see your parrain, sittin' on the Bayou,
My marraine told your parrain; I'm gonna set your flag on fire.

Watch all what you tell them to, Iko, Iko ahnday,
'Cos we ain't do, what you tell us to; now you can Jocamo feena nay

Chorus

D A
Talkin' 'bout; hey now, hey now! Iko, Iko ahnday,
D
Jocamo feena nay Jocamo feena nay

C7 G7
Iko, Iko ahnday, Jocamo feena nay
C7
Iko, Iko ahnday, Jocamo feena nay

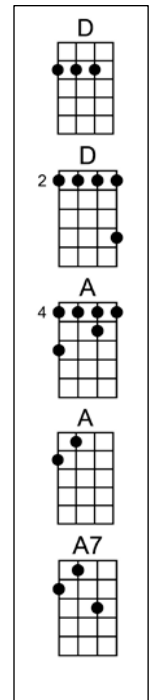

IN THE MIDNIGHT HOUR

PICKETT/CROPPER

First note=D

F D C Bb G C G C x2

I'm gonna wait 'till the midnight hour
 That's when my love comes tumbling down
 I'm gonna wait 'till the midnight hour
 When there' no one else around
 I'm gonna take you man and hold you
 Do all things I told you in the midnight hour – yes I am

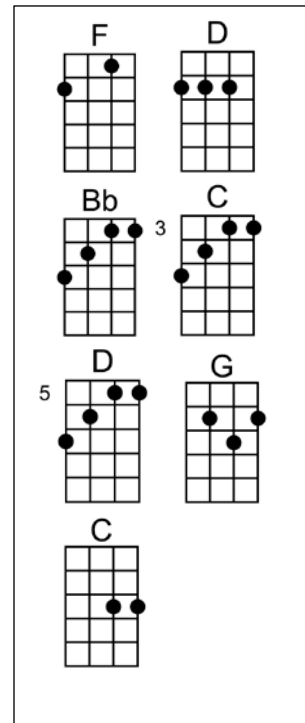

F D C Bb G C G C x2

I'm gonna wait till the stars come out
 See them twinkle in your eyes
 I'm gonna wait 'till the midnight hour
 That's when my love begins to shine
 You're the only guy I know
 Really love me so in the midnight hour
 Yeah, alright, play it for me one time

Harp Solo

Harp solo - simulate horn section
 I'm gonna wait 'till the midnight hour
 That's when my love comes tumbling down
 I'm gonna wait 'till the midnight hour
 When there' no one else around
 I'm gonna take you man and hold you
 Do all things I told you in the midnight hour – yes I am

↓ ↓ ↑↑ ↓ ↑↑ ↓ ↓ ↑↑ ↓ ↓ ↑ ↓ ↑ ↓
 1_6 1_6 55 4 55 1_6 1_6 55 4 5 6 5 6 5

↓ ↓ ↑↑ ↓ ↑ ↓ ↓
 1_6 1_6 55 4 5 3 3 **horn section**

then solo over melody, then repeat above

↑↑↑↑↑↑↑↑ ↓↓ ↓↓ ↓↓ ↓↓ ↓↓ ↓↓ ↓↓ ↓↓
 454666554 45445455 x2 2233332 x2 22222

F D C Bb G

IT HURTS ME TOO 1931 MEL LONDON & WALTER VINSON

C **C7**
 You said you was hurting, almost lost your mind,
F **Fm**
 And the man you love, he hurts you all the time.
C **G7** **C** **G7**
 When things go wrong, go wrong with you, it hurts me, too.

C **C7**
 You love him more when you should love him less.
F **Fm**
 I pick up behind him and take his mess.
C **G7** **C** **G7**
 When things go wrong, go wrong with you, it hurts me, too.

C **C7**
 He love another woman and I love you,
F **Fm**
 But you love him and stick to him like glue.
C **G7** **C** **G7**
 When things go wrong, go wrong with you, it hurts me, too.

First note=C

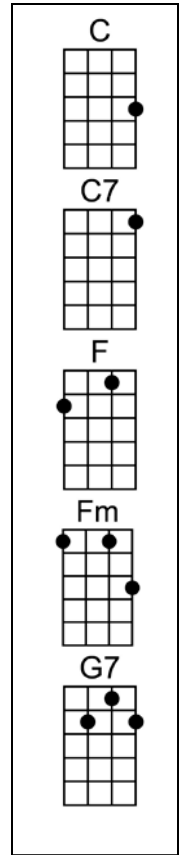

Solo

C **C7**
 Now you better leave him; he gonna put you down.
F **Fm**
 Oh, I won't stand to see you pushed around.
C **G7** **C** **G7**
 When things go wrong, go wrong with you, it hurts me, too.

Intro - turnaround

G7

C - PLAY SONG

A -3-3-3--3-3-3--3-3-3-3- | -2-2--2-2--2-2--2-2 | -3-----
 E -----1-----2-----3- | -1-1--1-1--1-1--1-1 | -0-----
 C -----0-----0----- | -2-2--2-2--2-2--2-2 | -0-----
 G -3-----2-----1-----0- | ----- | -0-----

You said you was hurtin'...

IT'S ALL OVER NOW

WOMACK

Intro below

Strum dD

First note=G

G

Well, baby used to stay out all night long,
 Made me cry, Lord she done me wrong.
 Hurt my eyes open, and that's no lie,
 Tables turnin', now it's her turn to cry,

D Db C G

Because I used to love her, but it's all over now.
 Because I used to love her, but it's all over now.

Solo

G

Well I used to wake the morning, get my breakfast in bed,
 When I got worried, you know she eased my achin' head,
 But now she's here and there with every man in town'
 Still tryin' to take for that same old clown.

D Db C G

Because I used to love her, but it's all over now.
 Because I used to love her, but it's all over now.

Solo

G

Well she used to run around with every man in town,
 Spend all my money, Lord, play her high class games
 Put me out, it was a pity how I cried,
 Table's turnin', now it's her turn to cry,

D Db C G

Because I used to love her, but it's all over now.
 Because I used to love her, but it's all over now.
 Yes and I used to love her, but it's all over now.

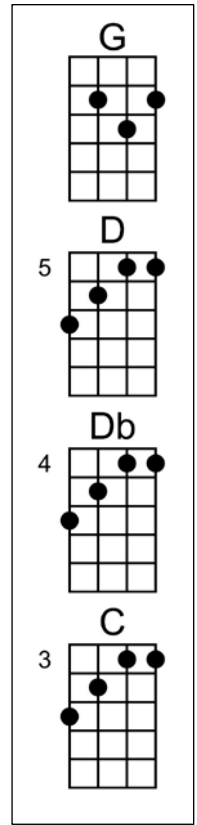

Intro		used to love her (to show solo spot)
A -----	-----	-10-10-12-10-----
E -----3-	-----	-----13-10-----
C -----4-2-4-2-4--	-2-4-2-----	-----12-10-12b13-12-10-----
G -4-3-2-----	-----3-4-0-	-----12-

KNOCKIN' ON HEAVEN'S DOOR

BOB DYLAN

Intro: G D Am7 G D C

Strum=D DU UD

First note=G

G D Am7

Ma take this badge off of me

G D C

I can't use it anymore

G D Am7

It's getting dark, too dark to see

Chorus

G D C

And I feel like I'm knocking on heaven's door

G D Am7

Knock, knock, knocking on heaven's door x4

G D Am7

Mama, put my guns in the ground

G D C

I can't shoot them anymore

G D Am7

That long black cloud is comin' down

Chorus

G D Am7

Mama wipe the blood from my face

G D C

I'm sick and tired of the war

G D Am7

Got a lone black feelin', and it's hard to trace

Chorus

G D Am7

Mama take these tears out of my eyes

G D C

I can't see through them anymore

G D Am7

Just for once, I'd like to see the sunrise

Chorus

Repeat first verse

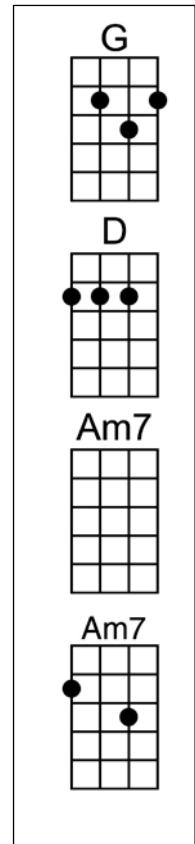

MAMA TRIED

MERLE HAGGARD

Intro: D A7 D or below

Strum=dD

First note=D

D G D G
 First thing I remember knowin' was that lonesome whistle blowin'
 D A7
 And a young un's dream of growin' up to ride.
 D G D G
 On a freight train leavin' town, not knowin' where I was bound
 D A7 D
 No one could steer me right, but mama tried.

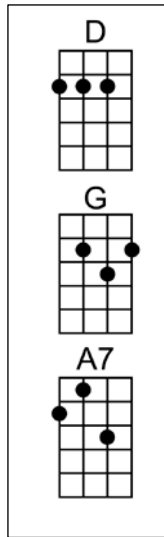

D G D G
 Was the only rebel child from a family meek and mild
 D A7
 Mama seemed to know what lay in store
 D G D G
 In spite of all my Sunday learnin' for the bad I kept on turnin'
 D A7 D
 Mama couldn't hold me anymore.

Intro
 A -----0-2-0-----
 E -----0-2-----2-0--2-0---
 C ---2-----2-----
 G -2-----

Chorus

D C D
 And I turned 21 in prison, doin' life without parole
 Bm A7
 No one could steer me right, but mama tried, mama tried
 D G D
 Mama tried to raise me better, but her pleadin' I denied
 A7 D
 That leaves no one but me to blame cause mama tried.

D G D G
 Dear old daddy rest his soul, left my mom a heavy load
 D A7
 She tried so very hard to fill his shoes
 D G D G
 Workin' hours without rest, wanted me to have the best
 D A7 D
 She tried to raise me right, but I refused.

Chorus

D A7 D
 That leaves no one but me to blame cause mama tried.

MORNING DEW

BONNIE DOBSON

Intro: C G D x3

Strum= D DUD D D D DUD

First Note=D

D C G D
Walk me out in the morning dew my honey,

D C G D
Walk me out in the morning dew today.

F C Em D
I can't walk you out in the morning dew my honey,

F C Em D
I can't walk you out in the morning dew today.

I thought I heard a baby cry this morning,
I thought I heard a baby cry this today.
You didn't hear no baby cry this morning,
You didn't hear no baby cry today.

Where have all the people gone my honey,
Where have all the people gone today.
There's no need for you to be worrying about all those people,
You never see those people anyway.

I thought I heard a young man moan this morning,
I thought I heard a young man moan today.
I thought I heard a young man moan this morning,
I can't walk you out in the morning dew today.

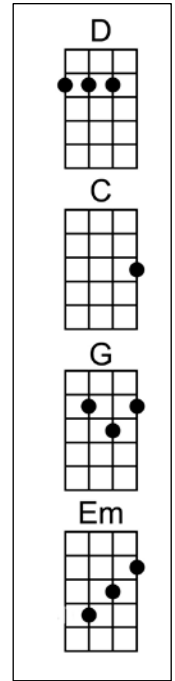

Riff - end of any line
 A -5p3-5-3-3p2-2-----
 E -----5-3-5-
 C -----
 G -----

Walk Up

D C G D
Walk me out in the morning dew my honey,
Walk me out in the morning dew today.
I'll walk you out in the morning dew my honey,

F C Em D
I guess it doesn't really matter anyway,
I guess it doesn't matter anyway,
I guess it doesn't matter anyway,
Guess it doesn't matter anyway. F C Em D +beginning of riff

Walkup	D
A -----5-5h7-9-10-12-15-12-15-16-17-5-	
E -----5-8-5-8-9-----5-	
C ---4-6-7-----6-	
G -7-----7-	

NEW MINGLEWOOD BLUES

1928

NOAH LEWIS

First note= E

D C D
I was born in the desert, raised in a lion's den
D C D
I was born in the desert, raised in a lion's den
A7 D7 D
My number one occupation, stealin' women from their men

D C A
Well, I'm a wanted man in Texas, busted jail and I gone for good
D C A
Well, I'm a wanted man in Texas, busted jail and I gone for good
E7 D A
Well the sheriff couldn't catch me, but his little girl sure wished she could

D C A
Now the doctor called me crazy, some says I am some says I ain't
D C A
Now the doctor called me crazy, some says I am some says I ain't
E7 D A
Yes and the preacher man call me sinner, but his little girl call me a saint

D C A
Well, a couple shots of whiskey, women round here start looking good
D C A
Well, a couple shots of whiskey, women round here start looking good
E7 D A
A couple more shots of whiskey, I'm going down to Minglewood

D C A
Well it's T for Texas, Yes and It's T for Timbaktu
D C A
Well it's T for Texas, Yes and It's T for Timbaktu
E7 D A
Yea, and it's T right here in C'ville, where the little girls know what to do

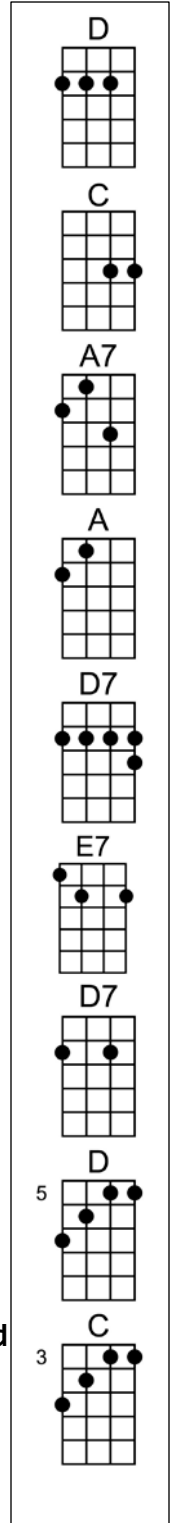

Repeat first verse

Intro D C -this lick or voiced higher works as turnaround

A	-----		-----	
E	-----3----		-2-0-2--0-2-0---2-0-2-	
C	-0-h2p0-----4~		-2-0-2--0-2-0---2-0-2-	
G	-----2-----		-2-0-2--0-2-0---2-0-2-	

Solo (play 1st 2 bars twice)

A		-----5-5-7-5-		-----5-----			-----3---3----		---3-5-3-----	
E		---5-----		-8-8-5-8-----			-3-4-5-5---5---5-5		-5-----3-1--	
C		-6-----		-----7-6-			-----		-----3	
G		-----		-----			-----		-----	

NOT FADE AWAY

CHARLES HARDIN & NORMAN PETTY

Intro: D GD till ready Strum= D DU UDUD D D
D G DD x4 Strum= D D UDD

First Note=D

D G C G
I wanna tell you how it's gonna be,
D G C G
You're gonna give your love to me,
D G C G
I wanna love you night and day,
D G C G
You know my love not fade away.
D G C G
You know my love not fade away,
G
Not fade away!

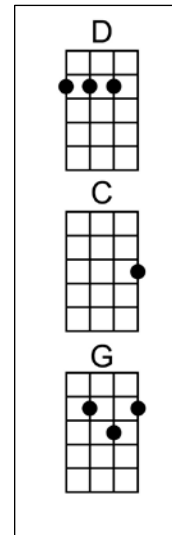

Solo over chords

G C G mostly occasionally move to D G D

D G C G
My love is bigger than a Cadillac,
D G C G
I try to show you but you drive me back,
D G C G
Your love for me has got to be real,
D G C G
For you to know just how I feel.
D G C G
A love is real, not fade away

Solo over chords then D G DD x4 as above

Then fade out over

D G C G
You know my love not fade away,

or then fade back in and repeat two verses as desired

Bo Diddley strum – above is a variation of this classic

1 + | 2 + | 3 + | 4 + | 1 + | 2 + | 3 + | 4
D | U | D | D | D | D | D |

SCARLET BEGONIAS

GARCIA/HUNTER

Intro: A D A G A x4

Strum=D DU UDU

First note=D

D A G
 As I was walkin' down Grosvenor Square,
 G D A G
 Not a chill to the winter but a nip to the air,
 G D A G D
 From the other direction she was calling my eye,
 G D A G D A
 Could be an illusion but I might as well try, might as well try.

She had rings on her fingers and bells on her shoes,
 And I knew without askin' she was into the blues.
 She wore scarlet begonias tucked into her curls,
 I knew right away she was not like other girls, other girls.

In the heat of the evening when the dealin' got rough,
 She was too pat to open and too cool to bluff.
 As I picked up my matches and was closin' the door,
 I had one of those flashes, I'd been there before, been there before.

Bridge

A E
 Well, I ain't often right but I've never been wrong,
 A G D
 Seldom turns out the way it does in the song.
 E
 Once in a while you get shown the light
 A G D E G A
 In the strangest of places if you look at it right.

Well, there ain't nothin' wrong with the way she moves,
 Her scarlet begonias or a touch of the blues.
 And there's nothing wrong with the look that's in her eyes
 I had to learn the hard way to let her pass by, let her pass by.

The wind in the willow's playing "Tea for Two,"
 The sky was yellow and the sun was blue,
 Strangers stopping strangers just to shake their hand,
 Everybody's playing in the heart of gold band, heart of gold band.

Outro

A G A D A G A x4

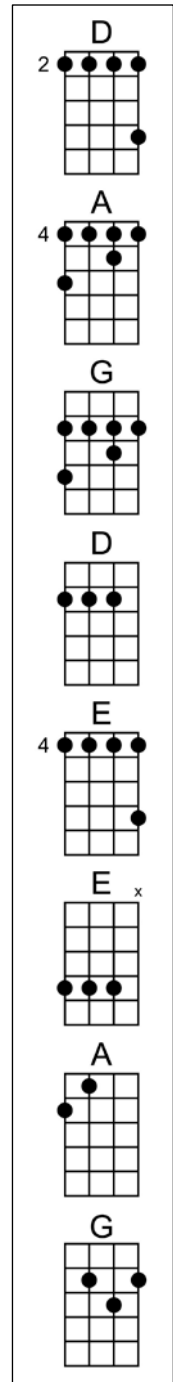

Walkdown Lick	
A	-5-5-5-4- -3-2-
E	-7-7-7-6- -5-3-
C	----- -----
G	----- -----

SEE SEE RIDER

1924

MA RAINEY & LENA ARANT

Intro: below

Strum=dD

First note=E

C C7
See see rider, see what you have done
F C
See see rider, see what you have done
G7 F C G7
You made me love you, now your man has come

C C7
Well, I'm going away, baby, I won't be back 'till fall
F C
I'm going away, baby, I won't be back 'till fall
G7 F C G7
If I find me a good girl, I won't be back at all

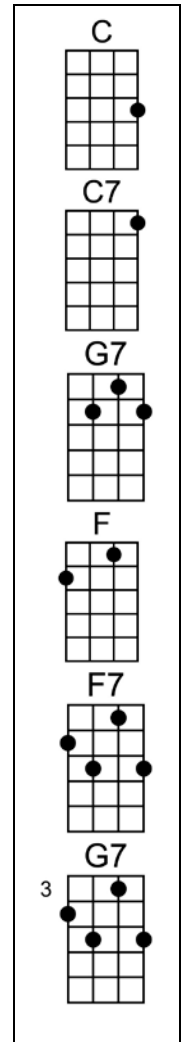

Solo

C C7
See see rider, where'd you stay last night?
F C
See see rider, where'd you stay last night?
G7 F C G7
Your shoes ain't tied and your clothes don't fit you right

C C7
See see rider, the moon is shinin' bright
F C
See see rider, the moon is shinin' bright
G7 F C F C
Just might find me a good girl an' everything will be alright

Intro/ turnaround

Alternate

C	G7	C	G7
A -3-3---3-3---3-3---3-	-2-2--2-2--2-2--2-2-	---3-----3-----3---3-	-2-2--2-2--2-2--2-2-
E -----	-1-1--1-1--1-1--1-1-	-0---0-1---1-2--2-3-	-1-1--1-1--1-1--1-1-
C -----	-2-2--2-2--2-2--2-2-	-----	-1-1--1-1--1-1--1-1-
G--3-3---2-2---1-1---0-	-----	-0-----2-----1-----0-	-----

Solo - work from melody line

A -----	-----	-----
E -0-----0-----	-----	--0-----0-----
C ---2-0-----2-0-----	-----2-0-2-3-2-0-----	---2-0---3---0-2-0-
G -----0-----0-3b4-	-0-1-2-----2-0-	-0-----2-----

SING ME BACK HOME

MERLE HAGGARD

Intro: below

Strum=D DU UD

First note=A

G D C G
 A warden led a prisoner - down the hallway - to his doom
 G D
 I stood up to say good-bye like all the rest
 G D C G
 And I heard him tell the warden just before he reached my cell
 G D G
 'Let my guitar playing friend do my request.'

G D C G
 Let him sing me back home with a song I used to hear
 G Gsus2 G Gsus4 G D A D
 Make my old memories come alive
 G D C G
 Sing me away and turn back the years
 G Gsus4 G C D G
 Sing me back home before I die

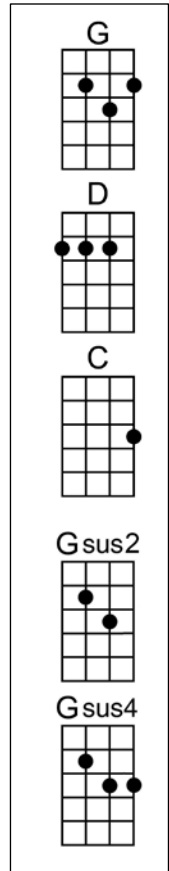

Solo over chorus chords

G D C G
 I recall last Sunday morning, a choir from off the streets
 G D
 Came in to sing a few old gospel songs
 G D C D G
 And I heard him tell the singers, There's a song my mama sang
 G D G
 Can I hear it once - before you move along?

G D C G
 Sing me back home with a song I used to hear
 G Gsus2 G Gsus4 G D A D
 Make my old memories come alive
 G D C G
 Sing me away and turn back the years
 G Gsus4 G C D G
 Sing me back home before I die

Intro

A	---	0-2-2	---	0-2-3	0-----	2-	
E	-3-	-----	3-2-3-3-				
C	-----					2-	
G	-----					0-	

SITTING ON TOP OF THE WORLD WALTER VINSON & LONNIE CHATMON

1930

First note=A

A
A7
 Was in the summer one early fall
D
D7
 Just tryin' to find my little all and all
A
E7
 Now she's gone an' I don't worry
A
E7
A
E7
 Lord, I'm sittin' on top of the world

One summer day, she went away
 She went and left me, now she gone to stay
 My baby's gone but I can't worry
 I'm sittin' on top of the world

Now don't come runnin', holdin' out your hand
 I'll get me a woman, quick as you can get a man
 Now she's gone an' I don't worry
 Lord, I'm sittin' on top of the world.

Worked all the summer, worked all fall
 Had to take Christmas, in my overalls
 But now she gone and I don't gonna worry
 I'm sittin' on top of the world

I'm going down to the station, down in the yard,
 Gonna catch me a freight train, work done got hard
 But now she gone and I don't worry
 I'm sittin' on top of the world

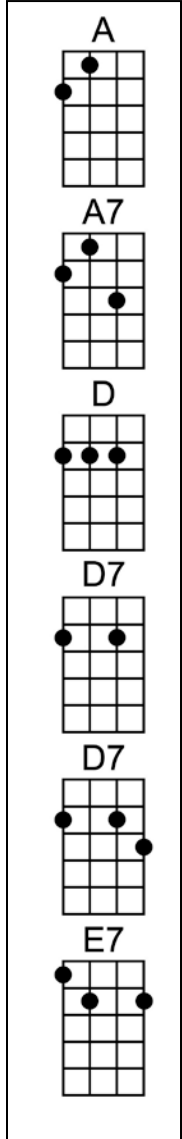

INTRO

WALKDOWN

E7

A	---	0---	0-----	0-----	0-----		-2-2--	2-2--	2-2--	2-2--	2-2--	2-2--	2-2--	2-2--	2-2--	2-2--	2-2--	2-2--	2-2--	2-2--	
E	----	3---	3-2---	2-1---	1-0-		-0-0--	0-0--	0-0--	0-0--	0-0--	0-0--	0-0--	0-0--	0-0--	0-0--	0-0--	0-0--	0-0--	0-0--	
C	-----	-----	-----	-----	-----		-2-2--	2-2--	2-2--	2-2--	2-2--	2-2--	2-2--	2-2--	2-2--	2-2--	2-2--	2-2--	2-2--	2-2--	
G	-2-----	-----	-----	-----	-----		-1-1--	1-1--	1-1--	1-1--	1-1--	1-1--	1-1--	1-1--	1-1--	1-1--	1-1--	1-1--	1-1--	1-1--	

STEALIN'

1921

CLARENCE WILLIAMS, GUS CANNON

First note= B

Intro D harp 3rd position or below

G

Now, put your arms around me like a circle 'round the sun

C

Stay with me baby like my easy rider done

G D G

If you don't think I love you look what a fool I've been

G D G G D G

If you don't think I'm sinking look what a hole I'm in

G G7 C C7

I'm stealin', stealin', pretty mama don't you tell on me

G F C D G C G

I'm stealin' back to my same old used-to-be

G

Well, the woman I love she's about my size

C

She's a married woman, comes to see me sometimes

G D G G D G

If you don't think I love you look what a fool I've been

G D G G D G

If you don't think I'm sinking look what a hole I'm in

G G7 C C7

I'm stealin', stealin', pretty mama don't you tell on me

G F C D G C G

I'm stealin' back to my same old used-to-be

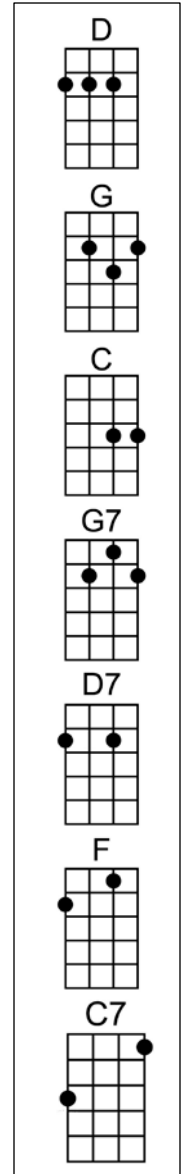

Intro

A -----2---0-----|
 E -----3---3-5-3-|
 C -1-/2--2-2---4-----|
 G -----4-----|

Solo

|-----5-|-----|
 |-7-5-7-5-7-5-7-5-7-|-6-5-5-----5---6-5-|
-----	-----7-7---7-7-

Solo continued

A -5-----5-----|10-10-8-8--7---7--7--7--7-10|-----|
 E ---7-5-----7-5---|-7---7---8-10-10-10--10-9|-----|
 C -----7-----7-|-7---7---7-----10|-----10-9-7-----7-9-7-|
 G -----|-7---7---9-----9|-7-9-7-----9-7-9-7-|

SUGAR MAGNOLIA

WEIR/HUNTER

Intro: G D D G

Strum=D DU UD

First note= B

G C G G F D G
 Sugar magnolia, blossoms blooming, heads all empty and I don't care.
 G Bm Em D C G D G
 Saw my baby down by the river, knew she'd have to come up soon for air

G C G G F D G
 Sweet blossom come on, under the willow, we can have high times if you'll abide.
 G Bm Em D C G D G
 We can discover the wonders of nature, rolling in the rushes down by the riverside.

C F C C G C
 She's got everything delightful, she's got everything I need.
 C F C C D G
 Takes the wheel when I'm seeing double, pays my ticket when I speed.

Solo

G C G G F D G
 She comes skimmin' through rays of violet. she can wade in a drop of dew.
 G Bm Em D C G
 She don't come and I don't follow, waits backstage while I sing to you.

G C G G F D G
 Well, she can dance a Cajun rhythm, jump like a Willys in four-wheel drive.
 G Bm Em D C G
 She's a summer love in the spring, fall and winter; she can make happy any man alive.

G F C G G F C G G F C G
 Sugar Magnolia, ringing that bluebell, caught up in sunlight.
 G D F C
 Come on out singing I'll walk you in the sunshine
 C G D G
 Ooh, come on honey, come along with me.

C F C C G C
 She's got everything delightful, she's got everything I need.
 C F C C D G
 A breeze in the pines in the summer night moonlight, crazy in the sunlight, yes indeed.

G C G G F D G
 Sometimes when the cuckoo's crying, when the moon is half way down,
 A D A A G D C G D A
 Sometimes when the night is dying, I take me out and I wander around,
 G D A

I walk around

A D A E D
 The sunshine daydream, walking in the tall trees.

A D A E D A
 Going where the wind goes, blooming like a red rose.

D A E D A
 Breathing more freely. Ride out singing, I'll walk you in the morning sunshine

E D A D
 Sunshine, daydream., sunshine, daydream

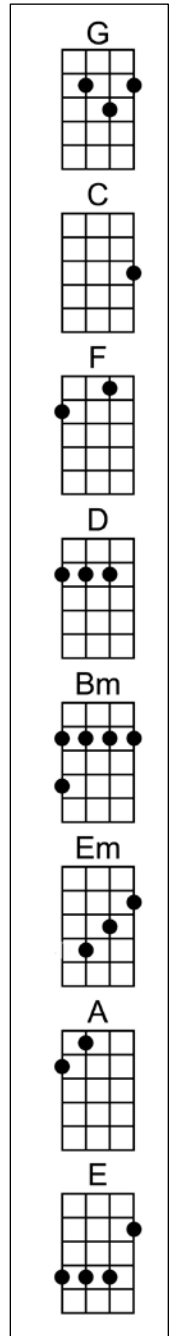

Melody solo beginning

A -----7-----
 E 7-10-10-7-10---10-7-10-----7-7-
 C -----9-7-7-9-----
 G -----

Intro...

G F D C

A -1/2--1/2---2---3-2-|

⁴³E -2/3--2/3-3---3-----|

SUGAREE

HUNTER/GARCIA

Intro: A D x3

Strum= dD

First Note=D

A D G D
 When they come to take you down
 A D G D
 when they bring that wagon 'round
 A D G D
 When they come to call on you
 A D
 and drag your poor body down

Chorus

Em Bm G D
 Just one thing I ask of you, just one thing for me
 A Bm G D
 Please forget you know my name, my darling sugaree
 A D Bm G D
 Shake it, shake it sugaree, just don't tell them that you know me
 A D Bm G D
 Shake it, shake it sugaree, just don't tell them that you know me
 Uke solo

You thought you was the cool fool
 and never could do no wrong
 Had everything sewed up tight.
 how come you lay awake all night long

Chorus

Well in spite of all you had gained
 you still had to stand out in the pouring rain
 One last voice is calling you
 and I guess it's time you go

Chorus

A D G D A D G D
 Well shake it up now sugaree, I'll meet you at the jubilee
 A D G D A D
 and if that jubilee don't come, well I'll meet you on the run

Chorus

Repeat last line 2 extra times

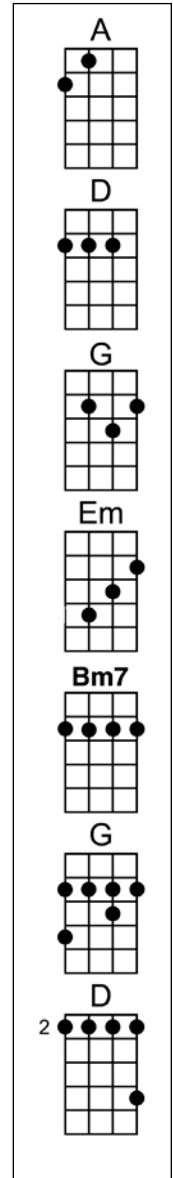

TENNESSEE JED

GARCIA/HUNTER

Intro: below

First note=G

C C G C
Cold iron shackles, ball and chain.
F G C C G C
Listen to the whistle of the evenin' train.
C Cdim7 Dm7 C C7
You know you, bound to, wind up dead.
F G C C G C
If you don't head back to Tennessee Jed.
C C G C
Rich man step on my poor head.
F G C C G C
When you get back, you better butter my bread.
C Cdim7 Dm7 C C7
Well you know it's, like I said.
F G C Bb F G C
Better head back to Tennessee Jed.

Chorus

F F C G F
Tennessee, Tennessee, there ain't no place I'd rather be.
C G F C G F G C
Baby won't you carry me... back to Tennessee.

Drink all day and rock all night.
Law come to get you if you don't walk right.
Got a letter this mornin' children and, all it read:
"You better head back to Tennessee Jed."
I dropped four flights and cracked my spine.
Honey, come quick with the iodine.
Catch a few winks, baby now, under the bed.
Then you head back to Tennessee Jed.

Chorus

I run into Charlie Fog.
Blacked my eye and he kicked my dog.
My doggie, turned to me, and he said.
"Let's head back to Tennessee Jed."
I woke up feelin' mean.
I went down to play the slot machine.
The wheels turned around and the, letters read:
"You better head back to Tennessee Jed".

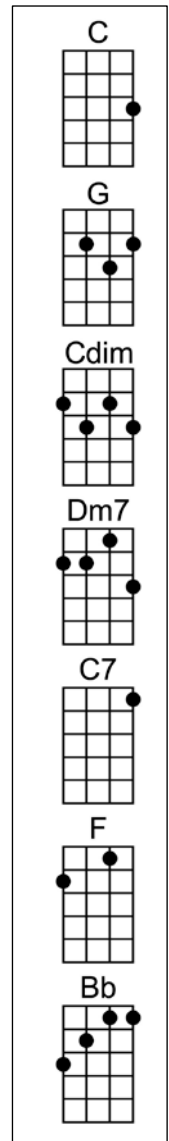

	Intro	also at end of line
A	-----	-7-7-5-3-----
E	-----	-----5-3-----
C	0-----0-----0-0-3b4-	-----3h4---
G	---0-2---0-2-----	-----5-

Chorus

F F C G F
Tennessee, Tennessee, there ain't no place I'd rather be.
C G F C G F G C
Baby won't you carry me... back to Tennessee.

TRUCKIN'

GARCIA/HUNTER

Chorus

Strum=D D UU D

D G
 Truckin' got my chips cashed in. Keep truckin', like the do-dah man
 A G D D7 (x4)
 Together, more or less in line, just keep truckin' on.

Verse

D
 Arrows of neon and flashing marquees out on Main Street.
 Chicago, New York, Detroit and it's all on the same street.
 Your typical city involved in a typical daydream
 Hang it up and see what tomorrow brings.

Chorus

D G
 Dallas, got a soft machine; Houston, too close to New Orleans;
 A G D D7 (x4)
 New York's got the ways and means; but just won't let you be.

Verse

D
 Most of the cats that you meet on the streets speak of true love,
 Most of the time they're sittin' and cryin' at home.
 One of these days they know they gotta get goin'
 Out of the door and down on the streets all alone.

Chorus

D G
 Truckin', like the do-dah man. Once told me "You've got to play your hand"
 A G D D7 (x4)
 Sometimes your cards ain't worth a dime, if you don't lay'em down,

Bridge

G C G F C G
 Sometimes the light's all shinin' on me;
 G F C G
 Other times I can barely see
 C Am E Gmaj7 D D7 (x4)
 Lately it occurs to me what a long, strange trip it's been.

First note=F#

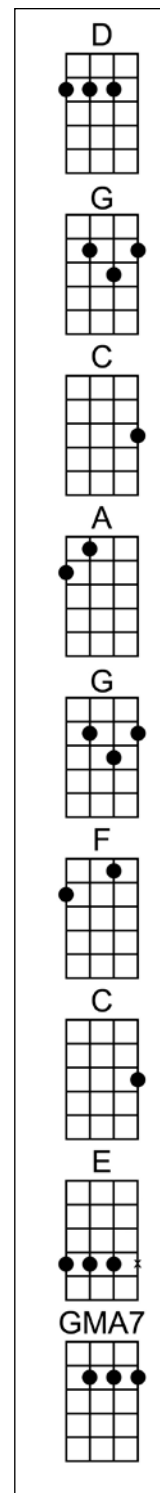

Verse

D

What in the world ever became of sweet Jane?
She lost her sparkle, you know she isn't the same
Livin' on reds, vitamin C, and cocaine,
All a friend can say is "Ain't it a shame?"

Chorus

D

G

Truckin', up to Buffalo. Been thinkin', you got to mellow slow

A

G

D D7 (x4)

Takes time, to pick a place to go, and just keep truckin' on.

Verse

D

Sittin' and starin' out of the hotel window.
Got a tip they're gonna kick the door in again
I'd like to get some sleep before I travel,
But if you got a warrant, I guess you're gonna come in.

Chorus

D

G

Busted, down on Bourbon Street, Set up, like a bowlin' pin.

A

G

D D7 (x4)

Knocked down, it get's to wearin' thin. They just won't let you be.

Verse

D

You're sick of hangin' around and you'd like to travel;
Get tired of travelin' and you want to settle down.
I guess they can't revoke your soul for tryin',
Get out of the door and light out and look all around.

Bridge

G

F C G

F C G

Sometimes the light's all shinin' on me; Other times I can barely see.

C

Am

E

Gmaj7

D D7 (x4)

Lately it occurs to me What a long, strange trip it's been.

Chorus

D

G

Truckin', I'm a goin' home. Woa woa baby, back where I belong,

A

G

D D7 repeat until fade out.

Back home, sit down and patch my bones, and get back truckin' on..

TURN ON YOUR LOVE LIGHT

JOE SCOTT,

Intro below x2 then A7 D7 A7 Strum =D DU UDU

DEADRIC MALONE

D7 A7 D7 A7
 Without a warning you broke my heart
 D7 A7 D7 A7
 You took it, darlin' you tore it apart
 D7 A7 D7 A7
 You left me sitting in the dark, crying
 D7 A7 D7 A7
 You said, your love for me was dying
 D7 A7 D7 A7
 I'm begging you, baby, baby, please
 D7 A7 D7 A7
 I'm begging you baby, baby, please
 D7 A7 D7 A7
 Turn on the light, let it shine on me
 D7 A7 D7 A7
 Turn on your love light, let it shine on me
 D7 A7 D7 A7 D7 A7
 Let it shine, shine, shine, let it shine

D7 A7 D7 A7
 I get a little lonely in the middle of the night
 D7 A7 D7 A7
 I need you, darlin', to make things alright
 D7 A7 D7 A7
 Come on, baby, baby, please
 D7 A7 D7 A7
 I'm begging you, baby, on my knees
 D7 A7 D7 A7
 Turn on the light, let it shine on me
 D7 A7 D7 A7
 Turn on your love light, let it shine on me
 D7 A7 D7 A7 D7 A7
 Let it shine, shine, shine, let it shine

First note=A

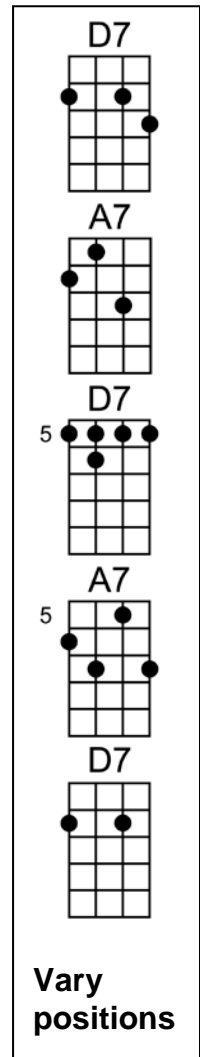

Solo	A G D
A ----- ---7-9-7-9-12-	
E -9-7----- -9-----	
C -----9-6-9- -----	
G ----- -----	

INTRO x6
A -----0-
E -----0---2---
C ---1---2---
G -2-----

WHISKEY IN THE JAR

TRADITIONAL IRISH

C **Am** **Intro:melody**
 As I was a goin' over Gilgarra mountain,
F **C** **Am**
 I met Colonel Pepper and his money he was counting
F **C** **Am**
 I drew forth my pistol and rattled my saber
F **C** **Am**
 Saying, "Stand and deliver, for I am a bold deceiver."

Strum=dD **First Note=E**

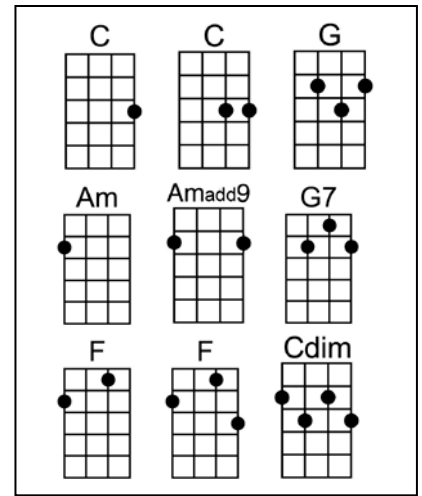

CHORUS – after each verse and at end

G **G7**
 Musha ringum duram da
C **C7**
 Whack! Fol de daddy-o
F **Cdim7**
 Whack! Fol de daddy-o
C **G7** **C**
 There's whiskey in the jar

Intro - Melody			
A	-----0-----	---0-0-2-0---	---0-0-0-2-3-2-0-----3-2-0---
E	-0-3-3---3-0-	-3-----3-	-3-----3-3-----0
C	-----	-----	-----
G	-----	-----	-----

The shining yellow coins did sure look bright and jolly
 I took the money home and I gave it to my Molly
 She promised and she vowed that she never would deceive me
 But the devil's in the women and they never can be easy

When I awoke between the hours of six and seven
 Guards were standing 'round me in numbers odd and even
 I flew to my pistol, but alas, I was mistaken
 I fired off my pistols and a prisoner was taken

They put me in jail without a judge or jury
 For robbing Colonel Pepper in the morning so early
 They didn't take my fist so I knocked down the sentry
 And I bid a long farewell to that cold penitentiary

Some take delight in fishing and bowling
 Others take delight in the carriage a rollin'
 I take delight in the juice of the barley
 Courting pretty women in the mornin' so early

Melody on harp

↑	↑↑↑	↓	↑	↑	↑	↓↓↓	↓	↓	↑		
6	777	7	7	6	7	777	8	7	6		
↑	↓↓↓	↓	↑	↓	↓	↑	↑	↑	φ	↓	↑
7	777	8	8	8	7	7	7	8	8	7	6
↑↑↑	↓	↑	↑	↑	↓↓↓	↓	↓	↑			
777	7	7	6	7	777	8	7	6			
↑	↓↓↓	↓	↑	↓	↓	↑	↑	↑	↓	↓	↑
6	777	8	8	8	7	7	7	8	8	7	6
↓	↑	↓	↑	↓	↑	↑↑↑	↑	↓	↑		
66	55	5	5	6	6	6666	6	7			
↓	↑	↓	↓	↑	↑	↑	↑	↓	↓	↑	
77	7	7	8	8	7	66	55	5			

Intro G - G D C G D C D

First note=G

G C G C G
Well the first days are the hardest days, don't you worry any more

C G C G
'Cause when life looks like easy street, there is danger at your door.

Am Em C D
Think this through with me, let me know your mind.

C D G D C G D G
Woh - oh, what I want to know, is are you kind?

C G C G
It's a buck dancer's choice my friend; better take my advice.

C G C G
You know all the rules by now, and the fire from the ice.

Am Em C D
Will you come with me, won't you come with me?

C D G D C G D G
Woh - oh, what I want to know, will you come with me?

G C G Am G D
Goddamn, well I declare, have you seen the like?

C Em G D C D
Their walls are built of cannonballs, their motto is don't tread on me.

G C Am G D
Come hear Uncle John's Band, playing to the tide

C Em G D C D
Come with me, or go alone, he s come to take his children home

Interlude G D C D x4

G C G C G
It's the same story the crow told me; it's the only one he knows.

C G C G
Like the morning sun you come, and like the wind you go.

Am Em C D
Ain't no time to hate, barely time to wait

C D G D C G D G
Woh - oh, what I want to know, where does the time go?

C G C G
I live in a silver mine, and I call it Beggar's Tomb

C G C G
I got me a violin, and I beg you call the tune

Am Em C D
Anybody's choice, I can hear your voice.

C D C D C G D G
Woh - oh, what I want to know, how does the song go?

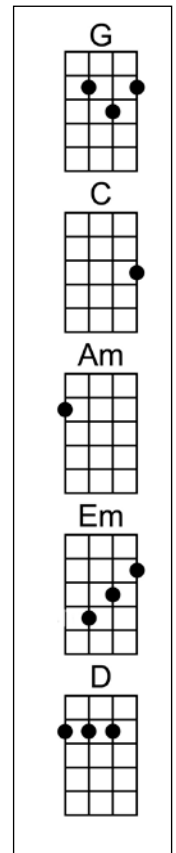

G C Am G D
Come hear Uncle John's Band, by the riverside
C Em G D C D
Got some things to talk about, here beside the risin' tide
G C Am G D
Come hear Uncle John's Band, playing to the tide
C Em G D C D
Come on along or go alone, he s come to take his children home

C D C D C G D G
Woh - oh, what I want to know, how does the song go?

G C Am G D
Come hear the Uncle John's Band, by the riverside
C Em G D C D
Got some things to talk about, here beside the risin' tide

G C Am G D
Come hear Uncle John's Band, playing to the tide
C G D C D
Come on along or go alone, he s come to take his children home

Outro:

G C G
Wo, oh, what I want to know, how does the song go..

AND WE BID YOU GOODNIGHT

TRADITIONAL

Intro: play melody as below

First note=A

Verse

D
Lay down, my dear brothers. Lay down and take your rest.

D A
Oh, won't you lay your head upon your savior's breast.

D G D
I love you, but Jesus loves you the best.

G A D
And I bid you goodnight, goodnight, goodnight

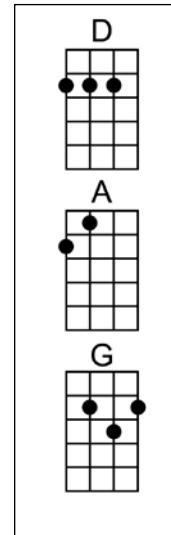

Repeat verse

D G A D
Walking in Jerusalem just like John (goodnight, goodnight, goodnight)

G A D
I remember right well, I remember right well (goodnight, goodnight, goodnight)

G A D
I go walking in the valley of the shadow of death,
and we bid you goodnight, goodnight, goodnight

Repeat verse

G A D
And we bid you goodnight, goodnight, goodnight

Intro - melody			
A	-----	-----0-0-	-----0-0---0-0----
E	-2-0-----	-----2-----	---0-2-----2-----2-0-
C	-----2-2-----	-----2-4-----	-2-----
G	-----4-2-4-	-2-4-----	-----
A	--0-----	-----	-----
E	-2--3---2-0-----	-----	-2-----
C	-----2-----2-----	-----2---2-	---4-----2-
G	-----4-2-	-2-2-4---4---	-----2-4---